



**Newland**

SCANNING MADE SIMPLE



**EM20-80V2**

OEM scan engine

integration guide

# Disclaimer

© 2021 Fujian Newland Auto-ID Tech. Co., Ltd. All rights reserved.

Please read through the manual carefully before using the product and operate it according to the manual. It is advised that you should keep this manual for future reference.

Do not disassemble the device or remove the seal label from the device, doing so will void the product warranty provided by Fujian Newland Auto-ID Tech. Co., Ltd.

All pictures in this manual are for reference only and actual product may differ. Regarding to the product modification and update, Fujian Newland Auto-ID Tech. Co., Ltd. reserves the right to make changes to any software or hardware to improve reliability, function, or design at any time without notice. The information contained herein is subject to change without prior notice.

The products depicted in this manual may include software copyrighted by Fujian Newland Auto-ID Tech. Co., Ltd or third party. The user, corporation or individual, shall not duplicate, in whole or in part, distribute, modify, decompile, disassemble, decode, reverse engineer, rent, transfer or sublicense such software without prior written consent from the copyright holders.

This manual is copyrighted. No part of this publication may be reproduced, distributed or used in any form without written permission from Newland.

Fujian Newland Auto-ID Tech. Co., Ltd. reserves the right to make final interpretation of the statement above.

Fujian Newland Auto-ID Tech. Co., Ltd.

3F, Building A, No.1, Rujiang West Rd., Mawei, Fuzhou, Fujian, China 350015

<http://www.newlandaidc.com>

---

## Revision History

Version	Description	Date
V1.0.0	Initial release.	May 05, 2019
V1.0.1	Updated the Table 2-1.	July 12, 2019
V1.0.2	Updated the Table 4-2 in 4-pin Box Connector	August 13, 2019
V2.0.0	Updated the Mounting section in Chapter 2. Updated the Table 3-1 and Figure 3-1 in Chapter 3 Updated Figure 4-1 in Chapter 4.	September 18, 2021



---

# Table of Contents

<b>Revision History</b> .....	<b>- 3 -</b>
<b>About This Guide</b> .....	<b>1</b>
Introduction .....	1
Chapter Description .....	1
Explanation of Symbols .....	1
Related Documents .....	2
<b>Chapter 1 Getting Started</b> .....	<b>3</b>
Introduction .....	3
Illumination.....	4
Good Read LED.....	4
Buzzer.....	4
Trigger.....	4
<b>Chapter 2 Installation</b> .....	<b>5</b>
Introduction .....	5
General Requirements.....	5
ESD .....	5
Dust and Dirt .....	5
Ambient Environment .....	5
Thermal Considerations .....	6
External Optical Elements .....	6
Mounting .....	6
Housing Design.....	7
Optics.....	7
Window Placement.....	8
Window Material and Color .....	8
Coatings and Scratch Resistance .....	9
Window Size.....	10
Roll, Skew and Pitch .....	11
Ambient Light .....	11
Eye Safety .....	11
<b>Chapter 3 Electrical Specifications</b> .....	<b>12</b>
Power Supply.....	12

Ripple Noise.....	12
DC Characteristics.....	12
Operating Voltage / Current.....	12
I/O Voltage.....	13
Timing Sequence .....	13
Power Up and Power Down Timing Sequence .....	13
<b>Chapter 4 Interfaces.....</b>	<b>14</b>
Interface Pinouts .....	14
12-pin FPC Connector.....	14
4-pin Box Connector.....	15
Connector/Cable Specifications (Unit: mm) .....	16
12-pin FPC Connector.....	16
4-pin Box Connector.....	16
12-pin FFC Cable .....	17
Dedicated Cable for 4-pin Box Connector .....	18
External Circuit Design .....	20
Good Read LED Circuit.....	20
Beeper Circuit.....	21
Trigger Circuit .....	21
<b>Chapter 5 Auxiliary Tools .....</b>	<b>23</b>
EVK.....	23
EasySet.....	23

# About This Guide

## Introduction

The NLS-EM20-80 V2 OEM scan engines (hereinafter referred to as “the EM20-80 V2” or “the engine”) are armed with CMOS image capturer and the Newland patented **UIMG**<sup>®</sup>, a computerized image recognition system-on-chip, featuring fast scanning and accurate decoding on barcodes on virtually any medium-paper, magnetic card, mobile phones and LCD displays. The EM20-80 V2 can be easily integrated into OEM equipment or systems, such as handheld, portable, or stationary barcode scanners. The EM20-80 V2 offers fully open image acquisition interface, raw data interface and I/O interface, which enable users to easily develop their own applications with Newland’s SDK.

※ Note: This guide provides general instructions for the installation of the engine into a customer's device. Fujian Newland Auto-ID Tech. Co., Ltd. recommends an opto-mechanical engineer should conduct an opto-mechanical analysis before integration.

## Chapter Description

Chapter 1, Getting Started	Gives a general description of the EM20-80 V2.
Chapter 2, Installation	Describes how to install the engine, including installation information, housing design, optical, grounding, ESD, and environmental considerations.
Chapter 3, Electrical Specifications	Includes the electrical characteristics for the engine and timing sequences.
Chapter 4, Interfaces	Includes interface pinout and connector/cable specifications.
Chapter 5, Auxiliary Tools	Introduces useful tools you can use to test and evaluate the EM20-80 V2 as well as conduct secondary development.

## Explanation of Symbols

- This symbol indicates lists of required steps.
- ※ This symbol indicates something important to the readers. Failure to read the notice will not lead to harm to the reader, device or data.
- ⚠ This symbol indicates caution that, if ignored, may cause data or device damage or even personal injury.

---

## Related Documents

- 12-pin FPC connector specification, Xiamen MOS Electronic Technology Co., Ltd., Model: 0.5-18-12PBX-AL-P, <http://www.fjmos.com/>
- 4-pin box connector specification, Fuzhou Aoke Electronics Co., Ltd., Model: 1.25T-4AWB.

# Chapter 1 Getting Started

## Introduction

The EM20-80 V2 is an area image engine for barcode reading. It includes eight illumination LEDs, two Good Read LEDs, one 12-pin FPC connector and two 4-pin box connectors.

### LED Compliance Statement

The EM20-80 V2 complies with IEC 62471:2006 for LED safety.

The EM20-80 V2 contains:

- a CMOS image sensor and its lens
- 8 illumination LEDs
- 2 good read LEDs
- a buzzer
- a trigger
- a 12-pin FPC connector and two 4-pin box connectors.

**Figure 1-1** System Block Diagram

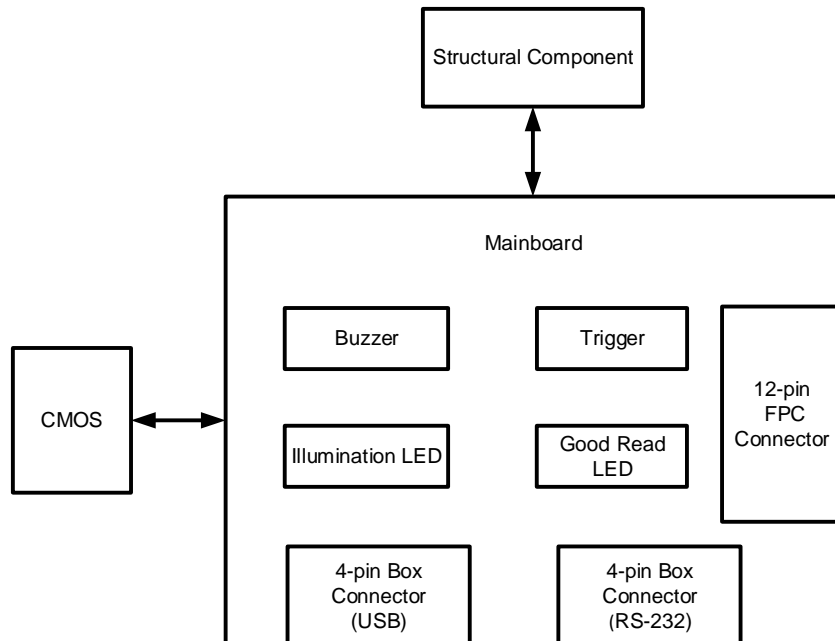

The 12-pin FPC connector/4-pin box connectors on the engine can be connected to a host device with an appropriate cable.

---

## **Illumination**

The EM20-80 V2 has eight LEDs for supplementary lighting, making it possible to scan barcodes even in complete darkness. The illumination can be programmed On or Off.

## **Good Read LED**

The EM20-80 V2 provides two green LEDs to indicate good read status. The Good Read LED can be programmed On or Off, and its ON time is also programmable by the user. To learn how to program these parameters, please see the EM20-80 V2 user guide.

## **Buzzer**

The EM20-80 V2 provides a buzzer to indicate power-on and good read statuses. The Power On Beep and Good Read Beep can be programmed On or Off, and the Good Read Beep Volume, Duration and Frequency are also programmable by the user. To learn how to program these parameters, please see the EM20-80 V2 user guide.

## **Trigger**

The EM20-80 V2 is equipped with a trigger which can be used to activate the engine to scan and to facilitate easier testing and debugging.

# Chapter 2 Installation

## Introduction

This chapter explains how to install the EM20-80 V2, including general requirements, housing design, and physical and optical information.

⚠ Caution: Do not touch the imaging lens when installing the engine. Be careful not to leave fingerprints on the lens.

⚠ Caution: Do not touch the illumination LED during handling. Improper handling may damage the LED.

## General Requirements

### ESD

ESD protection has been taken into account when designing the EM20-80 V2. However, due to limited board space, additional ESD protection, such as TVS protection, is not provided on the engine's I/O interface. It is advised to take corresponding protection measures when integrating the engine.

The engine is shipped in ESD safe packaging. Always exercise care when handling the engine outside its package. Be sure grounding wrist straps and properly grounded work areas are used.

### Dust and Dirt

The EM20-80 V2 must be sufficiently enclosed to prevent dust particles from gathering on the lens and circuit board. Dust and other external contaminants will eventually degrade the engine's performance.

### Ambient Environment

The following environmental requirements should be met to ensure good performance of the EM20-80 V2.

**Table 2-1**

Operating Temperature	-40°C to 65°C
Storage Temperature	-40°C to 75°C
Humidity	5% ~95% (non-condensing)

---

## Thermal Considerations

Electronic components in the EM20-80 V2 will generate heat during the course of their operation. Operating the EM20-80 V2 in continuous mode for an extended period may cause temperatures to rise on CPU, CIS, LEDs, DC/DC, etc. Overheating can degrade image quality and affect scanning performance. Given that, the following precautions should be taken into consideration when integrating the EM20-80 V2.

- ✧ Avoid continuous use of the LED for prolonged periods.
- ✧ Reserve sufficient space for good air circulation in the design.
- ✧ Avoid wrapping the EM20-80 V2 with thermal insulation materials such as rubber.

## External Optical Elements

Do not subject external optical components on the engine to any external force. Do not hold the engine by an external optical component, which may cause the mechanical joints that secure the components to crack or break due to excessive stress.

## Mounting

The illustrations below show the mechanical mounting dimensions (unit: mm) for the EM20-80 V2.

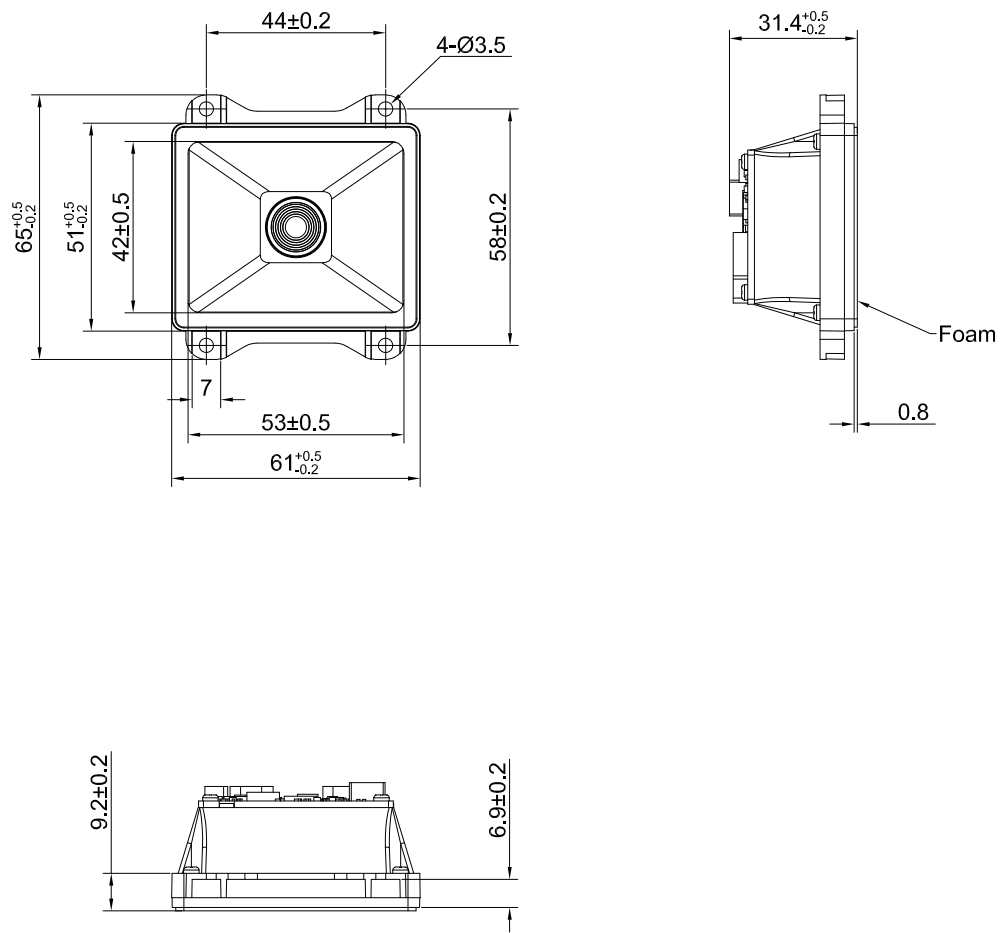

Figure 2-1

## Housing Design

※ Note: Conduct an optical analysis for the housing design to ensure optimal scanning and imaging performance.

Housing design should make sure that internal reflections from the aiming and illumination system are not directed back to the engine. The reflections from the housing or window can cause problems. Avoid any highly reflective objects around the engine that can cause bright spots to appear in the captured image. It is recommended to use baffles or matte-finished dark internal housing colors.

## Optics

The EM20-80 V2 uses a sophisticated optical system. An improperly designed internal housing or improper selection of

---

window material can degrade the engine's performance.

## Window Placement

The window should be positioned properly to let the illumination and aiming beams pass through as much as possible and no reflections back into the engine (reflections can degrade the reading performance).

The window should be mounted directly against the front of the engine (parallel,  $a=0$ ).

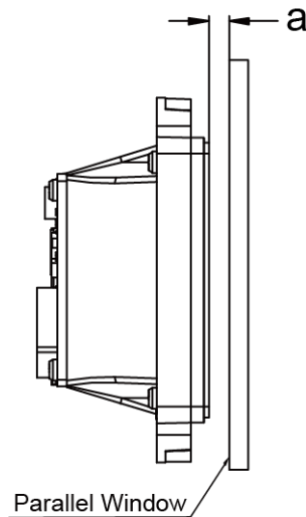

Figure 2-2

## Window Material and Color

Window material must be clear. Use only cell-cast plastics or optical glass. PMMA, ADC and chemically tempered glass are recommended. Window material selected for the engine should meet or exceed the specifications specified in **Table 2-2**. When using a clear plastic window, it is recommended to apply anti-reflection (AR) coating on it.

- **PMMA (Cell-cast acrylic):** When fabricated by cell-casting, has very good optical quality and low initial cost, but surface must be protected from the environment due to its susceptibility to attack by chemicals, mechanical stresses, and UV light. Reasonably good impact resistance. This material can be laser-cut into odd shapes and ultrasonically welded.
- **ADC (CR-39):** A thermal-setting plastic produced by the cell-casting process. Excellent chemical and environmental resistance. Quite good surface hardness, and therefore does not have to be hard-coated. Reasonably good impact resistance. This material cannot be ultrasonically welded.
- **Chemically tempered glass:** Glass is a hard material which provides excellent scratch and abrasion resistance. But unannealed glass is brittle. Increased flexibility strength with minimal optical distortion requires chemical tempering. Glass is hard to be cut into odd shapes and cannot be ultrasonically welded.

**Table 2-2**

Specification	Description
Spectral Transmittance	≥92%
Thickness	0.8-2.0mm
Wavefront Distortion	PV maximum: 0.2λ RMS maximum: 0.04λ
Clear Aperture	1.0mm to edges
Surface Quality	60-20 scratch/dig

Pay extra attention to the wavefront distortion when using plastic materials. Colored windows are not recommended if the engine is used to scan barcodes on moving objects.

## Coatings and Scratch Resistance

Scratch on the window can greatly reduce the performance of the EM20-80 V2. It is suggested to use abrasion resistant window material or coating.

The following introduces two commonly-used types of coatings:

- **Anti-reflection coatings:** Anti-reflection (AR) coatings can be applied to window surfaces to reduce reflected light from the window back into the engine. But they are expensive and have poor abrasion/scratch resistance.
- **Polysiloxane coatings:** Polysiloxane coatings can be applied to plastic surfaces to increase the surfaces' abrasion and scratch resistance.

Both tempered glass and plastic windows can be AR coated. However, it is easier and more cost-effective to put an AR coating on the glass than on the plastic.

The AR coating specifications below should be met when using an AR coated window.

Single side AR coating: 92% minimum transmittance within spectrum range from 420 nm to 730 nm.

Double side AR coating: 97% minimum transmittance within spectrum range from 420 nm to 730 nm.

---

## Window Size

The window must not block the field of view and should be sized to accommodate the aiming and illumination envelopes shown below.

Horizontal:

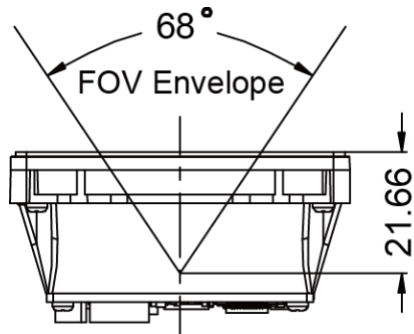

Figure 2-3

Vertical:

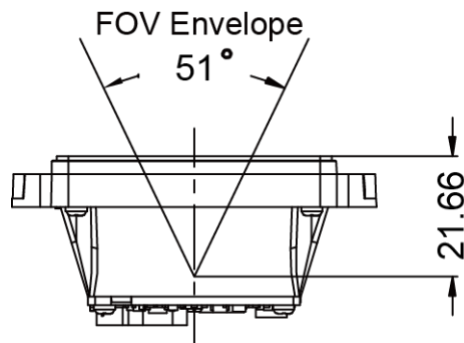

Figure 2-4

---

## Roll, Skew and Pitch

Three different reading angles, roll, skew and pitch are illustrated in **Figure 2-7**. Roll refers to rotation around the Z axis, skew to rotation around the X axis and pitch to rotation around the Y axis. For the engine's technical specifications, please visit the Newland website or contact your dealer.

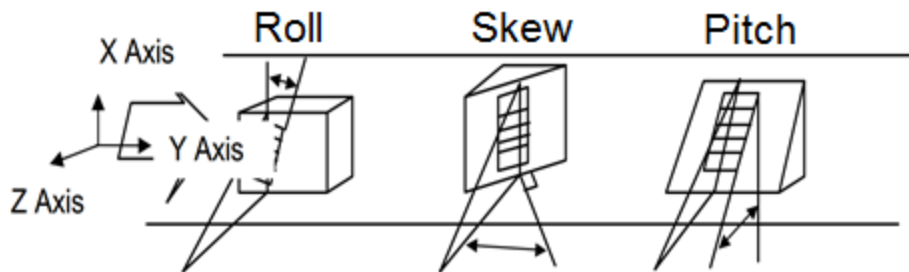

Figure 2-5

## Ambient Light

The EM20-80 V2 shows better performance with ambient light. However, high-frequency pulsed light can result in performance degradation.

## Eye Safety

The EM20-80 V2 has no lasers. It uses LEDs to produce illumination beam. The LEDs are bright, but testing has been done to demonstrate that the engine is safe for its intended application under normal usage conditions. However, the user should avoid looking into the beam.

## Chapter 3 Electrical Specifications

### Power Supply

Do not power up the EM20-80 V2 until it is properly connected. Be sure the power is cut off before connecting a cable to or disconnecting a cable from the host interface connector. Hot-plugging could damage the engine. Make sure that the FFC cable is horizontally inserted into the connector when installing the cable to connect the engine's 12-pin connector to the host.

Improper cable installation or unstable power supply or sharp voltage drops or unreasonably short interval between power-ons may lead to unstable performance of the engine. Do not resupply the power immediately after cutting it off.

### Ripple Noise

To ensure the image quality and engine performance, a power supply with low ripple noise is needed.

### DC Characteristics

#### Operating Voltage / Current

Table 3-1

T=23°C

Parameter	Description	Minimum	Typical	Maximum	Unit
Operating Voltage	VIN (12-pin FPC Connector)	3.0	3.3 or 5	5.5	V
	VIN (4-pin Box Connector)	3.0	3.3 or 5	5.5	V
Current (@5.0V)	Operating Current		151	268	mA
	Idle Current		62		mA
Current (@3.3V)	Operating Current		214	422	mA
	Idle Current		75		mA

## I/O Voltage

Table 3-2

VDD=3.3 V, VSS=0 V, T=23°C

Parameter	Minimum	Maximum	Unit
VIL	-0.3	0.8	V
VIH	2.0	3.6	V
VOL	VSS	0.4	V
VOH	2.4	VDD	V

## Timing Sequence

### Power Up and Power Down Timing Sequence

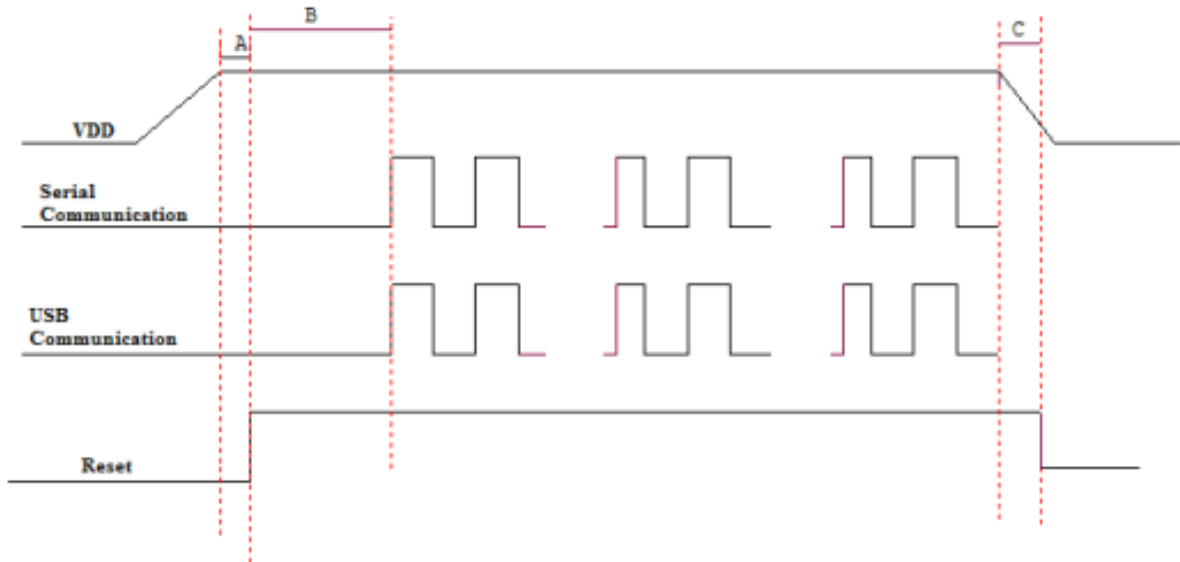

Figure 3-1

1. In the diagram above, it takes **A+B** (about 850ms) for the engine to power up: **A** is reset time (about 280ms), **B** is time needed to start the engine (including bootloader execution, kernel boot and decoding chip initialization). The engine is ready to receive commands via its serial/USB port after the power-up sequence completes.
2. **C** is the time it takes to power down the engine (during power-down, all voltages in the engine ramp down, with all communication stopped and all signals at a low level). To ensure that all voltages are fully down and signals on the interfaces at a low level, the minimum interval between removing and resupplying the power must exceed 700ms.

# Chapter 4 Interfaces

## Interface Pinouts

The physical interface of the EM20-80 V2 consists of a 12-pin FPC connector and two 4-pin box connectors:

- 12-pin FPC connector can be used as TTL-232 interface or USB interface.
- One 4-pin box connector can be used as standard USB interface and the other as RS-232 interface.

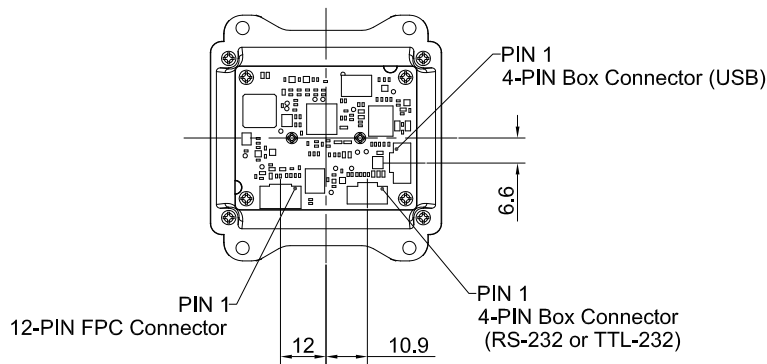

Figure 4-1

## 12-pin FPC Connector

The following table lists the pin functions of the 12-pin FPC connector.

Table 4-1

PIN#	Signal Name	I/O	Function	Remark
1	nTRIG	I	Trigger signal input: active low	See Note 1
2	nRESET	I	Reset signal input: active low	See Note 2
3	nGoodRead	O,od	Good Read LED output	See Note 3
4	nBEEPER	O,od	Beeper output	See Note 4
5	PWRDWN	-	No connection	
6	nRTS	O	TTL level 232 request to send	
7	nCTS/USB_D+	I	TTL level 232 clear to send/ USB D+ differential data signal	
8	TXD	O	TTL level 232 transmit data	
9	RXD/USB_D-	I	TTL level 232 receive data/ USB D- differential data signal	
10	GND	-	Power-supply ground	
11	VIN	-	Power supply input	
12	NC	-	No connection	

※ I = Input; O = Output; od = Open Drain;

※ 1 This external trigger signal can be either level trigger or pulse trigger.

**Level trigger:** A trigger pull (i.e. driving the nTRIG pin low for over 10ms) activates a decode session. The decode session continues until a barcode is decoded or the trigger is released.

**Pulse trigger:** When the trigger is pulled and released (pulse width : 50ms), scanning is activated until a barcode is decoded or the decode session timeout expires.

For the external trigger circuit, please see the “Trigger Circuit” section in this chapter. If the nTRIG pin is not used, leave it unconnected.

※ 2 Giving a 10µs low pulse on the nRESET pin will reset the engine. Normally this pin should be asserted high or in a high impedance state (there is a weak pull-up in the engine). The user may connect this pin to the GPIO of the host device when needing to use the reset function. If this pin is not used, leave it unconnected.

※ 3 This output signal can be used by an external LED to indicate good read status.

The nGoodRead pin produces a low output (default duration: 20ms, user-programmable) when a good read occurs. The Good Read LED can be programmed On or Off. To learn how to program these parameters, please see the EM20-80 V2 user guide.

For the external LED circuit design, please see the “Good Read LED Circuit” section in this chapter. If the nGoodRead pin is not used, leave it unconnected.

※ 4 This output signal can be used by an external beeper circuit to generate audible feedback to the user to indicate power-on and good read statuses.

**Power On beep:** The nBEEPER pin produces a PWM output (duration: 400ms; frequency: 4184Hz, both parameters are **NOT** user-programmable) 940ms after power-on. The beep can be programmed On or Off. To learn how to program the parameter, please see the EM20-80 V2 user guide.

**Good Read beep:** The nBEEPER pin produces a PWM output (default duration: 80ms; default frequency: 2730Hz, both parameters are user-programmable) when a good read occurs. The beep can be programmed On or Off. To learn how to program these parameters, please see the EM20-80 V2 user guide.

For the external beeper circuit design, please see the “Beeper Circuit” section in this chapter. If the nBEEPER pin is not used, leave it unconnected.

## 4-pin Box Connector

**Table 4-2**

4-pin box connector (RS-232 interface)

PIN#	Signal	I/O	Function
1	VIN	-	3.3V-5V power supply input
2	RS232-RXD	I	RS-232 receive data
3	RS232-TXD	O	RS-232 transmit data
4	GND	-	Power-supply ground

**Table 4-3**

4-pin box connector (USB interface)

PIN#	Signal	I/O	Function
------	--------	-----	----------

1	VIN	-	3.3V-5V power supply input
2	USB_D-	I/O	USB D- differential data signal
3	USB_D+	I/O	USB D+ differential data signal
4	GND	-	Power-supply ground

## Connector/Cable Specifications (Unit: mm)

The EM20-80 V2 is equipped with a 12-pin FPC connector and two 4-pin box connectors.

### 12-pin FPC Connector

The 12-pin FPC connector on the EM20-80 V2 is supplied by Xiamen MOS Electronic Technology Co., Ltd., Model No. 0.5-18-12PBX-AL-P, bottom contact.

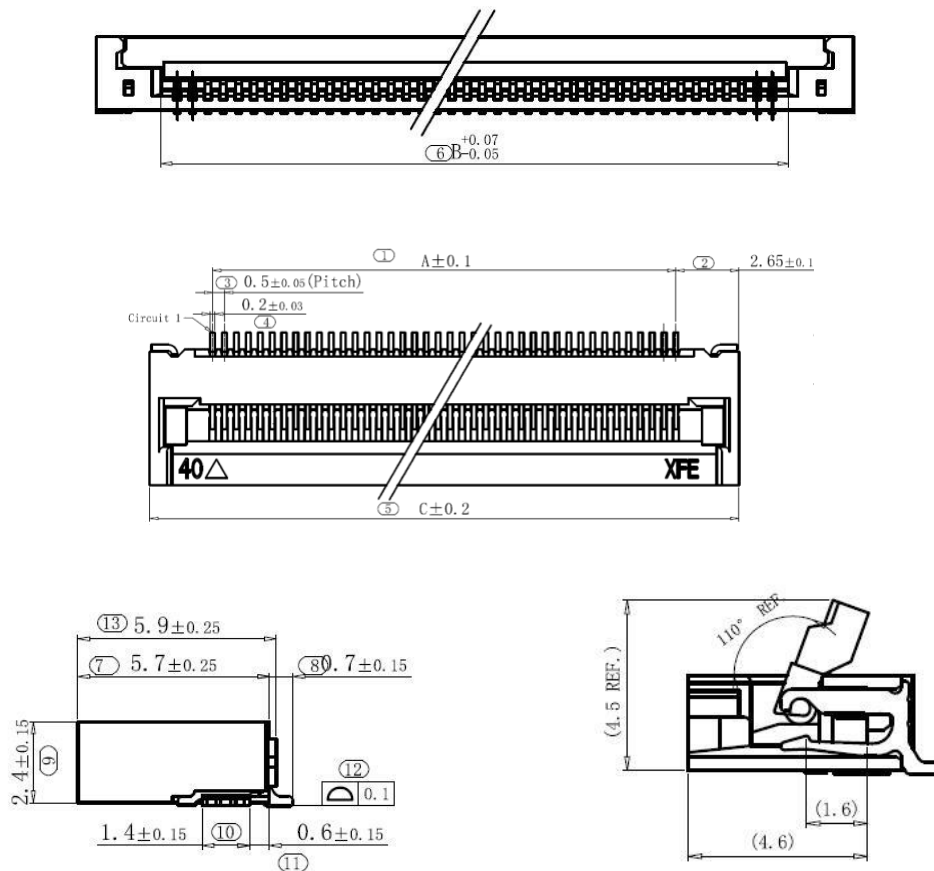

Figure 4-2

### 4-pin Box Connector

The two 4-pin box connectors on the EM20-80 V2 are supplied by Fuzhou Aoke Electronics Co., Ltd., Model No. 1.25T-4AWB.



**Figure 4-3**

**12-pin FFC Cable**

A 12-pin cable can be used to connect the engine's 12-pin FPC connector to a host device.

---

**Figure 4-4**

**Dedicated Cable for 4-pin Box Connector**

The dedicated cable can be used to connect the engine's 4-pin box connector to a host device.

Cable for 4-pin Box Connector (RS-232 interface):

---

**Figure 4-5**

Cable for 4-pin Box Connector (USB interface):

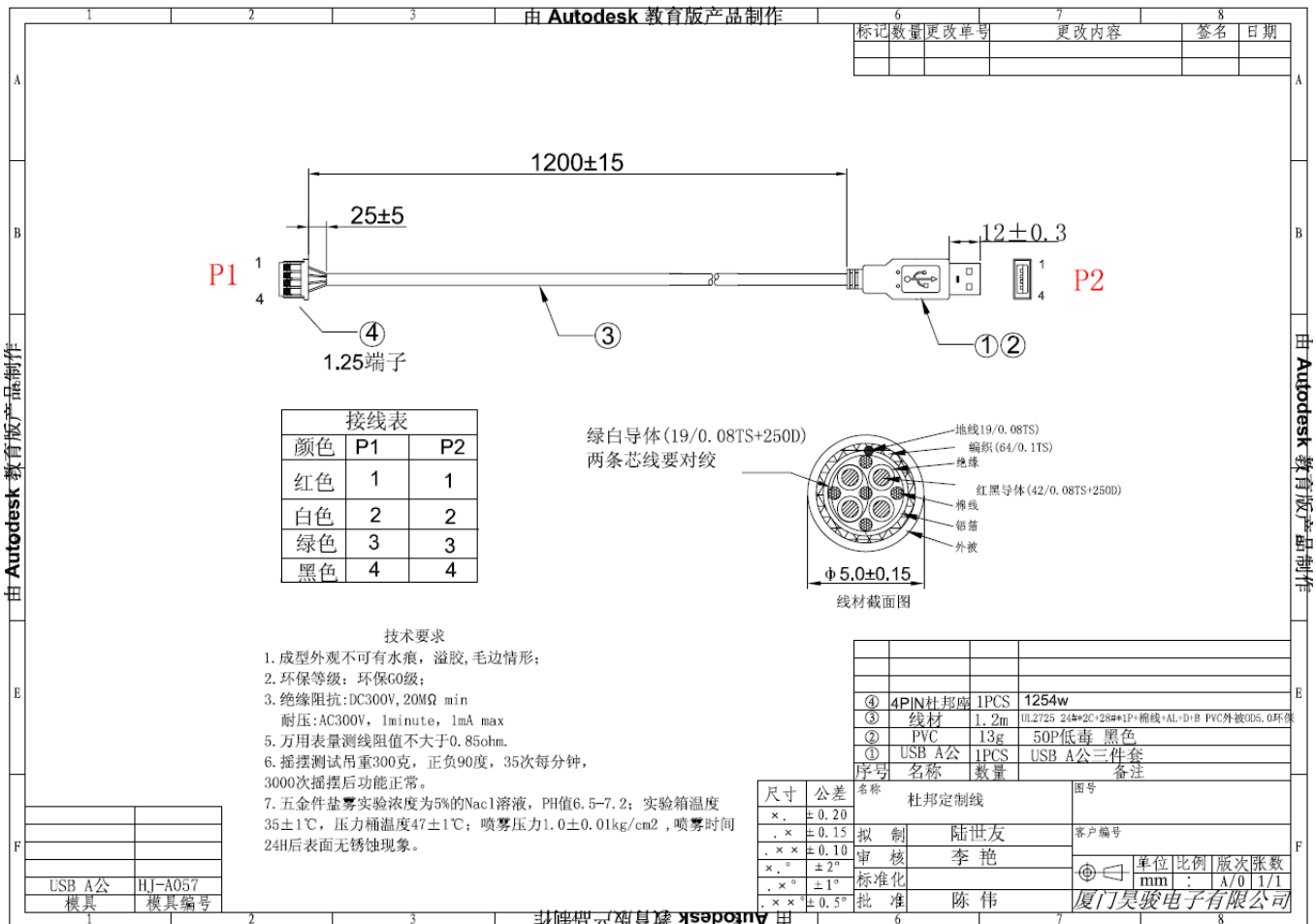

Figure 4-6

## External Circuit Design

### Good Read LED Circuit

The circuit below is used to drive an external LED for indicating good read. The left part shows internal LED driver circuit on the decoder board and the right part shows external circuit that users may utilize in actual application. The nGoodRead signal is from PIN 3 of the 12-pin FPC connector.

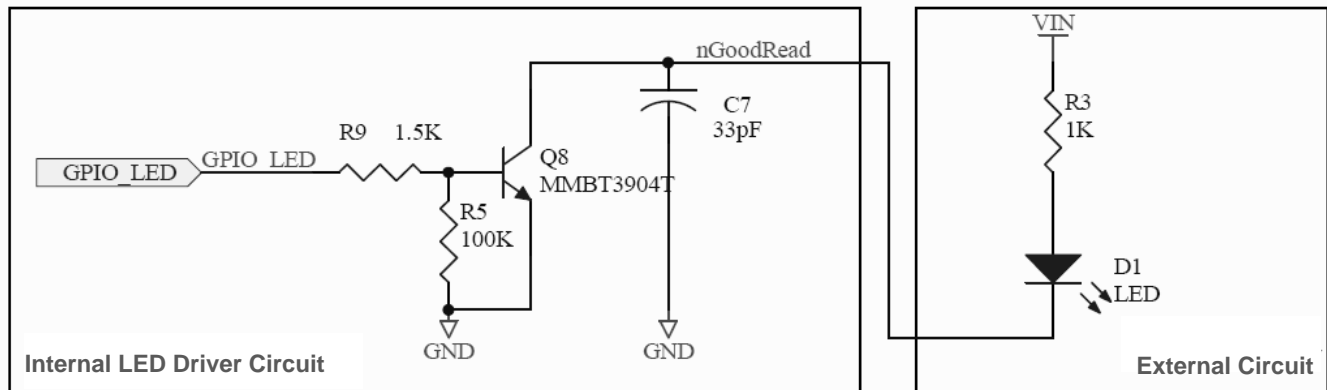

Figure 4-7

### Beeper Circuit

The circuit below is used to drive an external beeper. The left part shows internal beeper driver circuit on the decoder board and the right part shows external circuit that users may utilize in actual application. The nBEEPER signal is from PIN 4 of the 12-pin FPC connector.

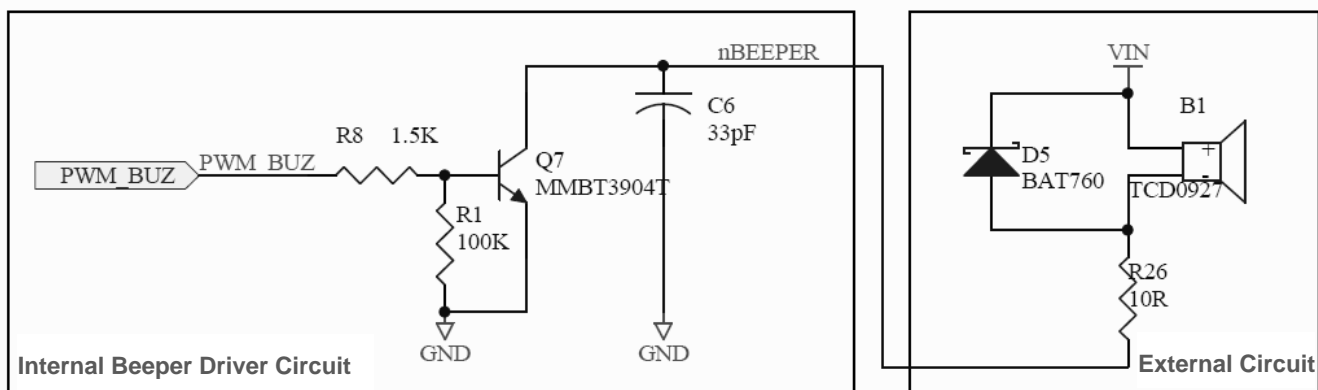

Figure 4-8

### Trigger Circuit

The circuit below is used to provide the engine with a signal to trigger a scan and decode session. The right part shows internal trigger processing circuit on the decoder board and the left part shows external circuit that users may utilize in actual application. The nTRIG signal is from PIN 1 of the 12-pin FPC connector.

Users can adjust the external circuit and its function as per actual needs, on condition that the external circuit matches the internal circuit.

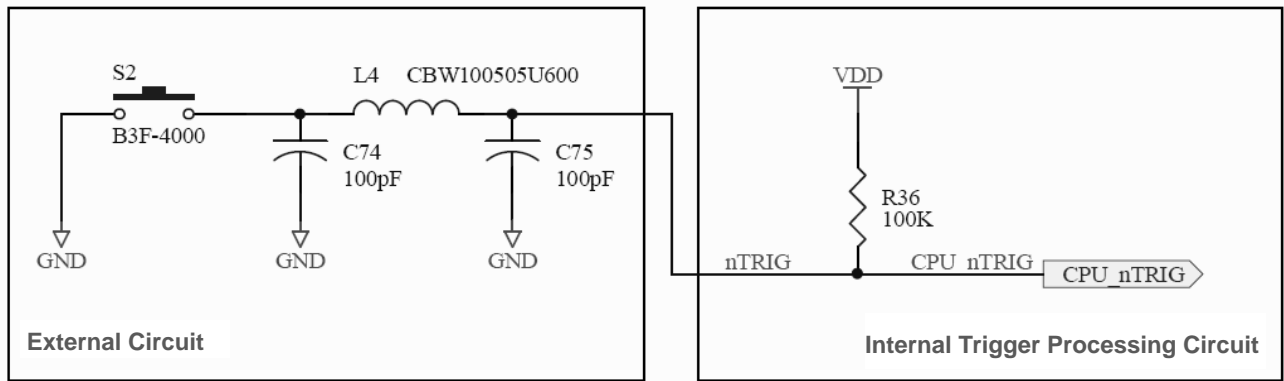

Figure 4-9

## Chapter 5 Auxiliary Tools

The EM20-80 V2 provides the following two tools to assist users in engine performance evaluation, application development and engine configuration.

### **EVK**

The EVK is provided to help users to test and evaluate the EM20-80 V2, which contains beeper & beeper driver circuit, LED & LED driver circuit, and trigger & reset buttons, TTL-232 to RS-232 converter & TTL-232 to USB converter, RS-232 & USB interfaces, etc. The EM20-80 V2 can be connected to the EVK via a 12-pin FFC cable type 1 (contacts on the same side). Either USB connection or RS-232 connection can be used when connecting the EVK to a host device.

### **EasySet**

EasySet is a Windows-based configuration tool developed by Newland, which can be used to configure the EM20-80 V2.



# Newland

SCANNING MADE SIMPLE

---

## Newland EMEA HQ

+31 (0) 345 87 00 33  
info@newland-id.com  
newland-id.com

## D-A-CH

0049 (0) 6182 82916-16  
info@newland-id.de

## Benelux

+31 (0) 345 87 00 33  
benelux@newland-id.com

## Italy

+39 (0) 342 0562227  
italy@newland-id.com

## United Kingdom

+44 (0) 7771 631387  
sales@newland-id.co.uk

## South Africa

Gauteng: +27 (0) 11 553 8010  
Cape Town: +27 (0) 21 9140819  
info@newland-id.co.za

## Turkey

+90 (0) 544 538 40 49  
turkey@newland-id.com

## France

+39 (0) 345 8804096  
france@newland-id.com

## Ibérica

+34 (0) 93 303 74 66  
info@newland-id.es

## Nordic & Baltic

+46 (0) 70 88 47 767  
nordic@newland-id.com

## Russia

+7 (495) 120-23-85  
russia@newland-id.com

## Middle East

+39 (0) 345 8804096  
middleeast@newland-id.com

## Iran

+90 (0) 544 538 40 49  
iran@newland-id.com