



Newland

SCANNING MADE SIMPLE



EM1300

OEM scan engine

integration guide

Revisions

Version	Description	Date
Pre-release	Initial release.	20090826
V 1.0	Support as from EM1300 firmware Version 1.13.7 and higher.	20100520
V 1.1	Revise the depth of field on the basis of testing report.	20100817
V 1.2	Revise the pictures of Dimensions.	20100902
V 1.2.1	Revise the pictures of Dimensions, Correct the setting code of "Disable ITF-6" and "Enable ITF-6, Do Not Transmit Check Digit", Correct "Min Message Length" of ITF25, Code39, COOP25, Matrix 25, Codabar, MSI and Code11.	20110610
V 1.2.2	Add an "ASCII Table" in <i>Appendix</i> .	20110823
V 1.2.3	Correct the table of "Interface Socket Pin Assignment and Definition" in <i>Chapter Mechanical Interface</i> .	20110914
V 1.2.4	Revise the Factory Default List.	20111103
V 1.3	Add the Enable/Disable All Symbologies, Auto Sleep in Hand-held Mode, Timeout between Decodes (Same Barcode) in Continuous Mode Features. Change the supported minimum lengths of Plessey and MSI-Plessey to 4; change that of Interleaved 2 of 5 to 2.	20131128
V 1.3.1	Add the feature of programming timeout between decodes (same barcode) for Continuous mode.	20140221
V 1.3.2	Add the Transmit UPC-E/UPC-A Preamble Character features. Change the supported minimum length of Code 39 to 1.	20140521



© 1999-2014 by Newland Auto-ID Tech. Co., Ltd, All rights reserved.

No part of this publication may be reproduced, transmitted, or used in any form or by any means, electrical or mechanical, without prior written permission from Newland Auto-ID. The material in this manual is subject to change without notice.

All software, including firmware, is provided strictly on an “as is” basis and is provided without further warranty. Newland Auto-ID grants to the user a non-transferable and non-exclusive license to use each software or firmware program delivered hereunder (licensed program). Except as noted below, such license may not be assigned, sublicensed, or otherwise transferred by the user without prior written consent of Newland Auto-ID. No right to copy a licensed program in whole or in part is granted except as permitted under copyright law or as hereinafter expressly provided. The user agrees to maintain Newland Auto-ID’s copyright notice on the licensed programs delivered hereunder, and to include the same on any authorized copies it makes in whole or in part. The user agrees not to decompile, disassemble, decode, or reverse engineer any licensed program or product delivered to the user or any portion thereof.

Newland Auto-ID reserves the right to make changes and improvements to any software or product for reliability, function, or design.

Newland Auto-ID does not assume any responsibility or liability arising out of, or in connection with, the application or use of any product, circuit, or application described herein.

No license is granted, either expressly or implicitly, estoppels, or otherwise under any Newland Auto-ID intellectual property rights. An implied license only exists for equipment, circuits, and subsystems contained in Newland Auto-ID products.

Microsoft and Windows are either registered trademarks or trademarks of Microsoft Corporation. All other product or service names are the property of their respective owners.

Newland Auto-ID Tech. Co., Ltd.



Contents

About this guide

Introduction 1
 Chapter Description 1
 Graphic Notations 1
 Newland Auto-ID Support Center 2

About EM1300

Introduction 3
 Highlights of the EM1300 3
 Get Familiar With EM1300 4
 Unpacking 4
 Outline of EM1300 4

Mechanical Interface

Introduction 5
 Dimensions of EM1300 Unit 6
 EM1300 Front View 6
 EM1300 Left Side View 6
 EM1300 Bottom View 6
 Interface 7
 Interface Socket 7
 Interface Cable 7
 Interface Socket Pin Assignment and Definition 8
 Schematic of Interface Socket 9
 Interface Flexible Cable Specifications 10
 Housing Design Considerations 11
 Housing Structure 11
 Scan Window 11

Electrical Interface

Introduction 12
 Interface Signal levels 13
 Input signals 14
 Trigger Input 14
 A Sample Schematic of Trigger Input Circuit 14
 Output Signals 15
 LED Output 15
 Beeper Output 15
 Inter-Character Timeout 15
 A Sample Schematic of LED Circuit 16
 A Sample Schematic of Beeper Circuit 16





EM1300 Development Tools

Introduction..... 17
 EM1300 Evaluation Kit, EVK3000 V2..... 18

General Programming

Introduction..... 19
 Code Programming..... 19
 Command Programming..... 19
 Programming Notation..... 20
 Code Programming..... 21
 Command Programming..... 22
 Default..... 24
 Factory Default..... 24
 Working Mode..... 25
 Reading Mode..... 26
 Hand-held Mode..... 26
 Auto Mode..... 27
 Interval Mode..... 28
 Sensor Mode..... 29
 Continuous Mode..... 31
 Delayed Sensor Mode..... 32
 Command Triggered Mode..... 33
 Security Level..... 34
 Beeper..... 35
 Others..... 36
 Start/Stop Temporary Mute..... 36

Query Command

Introduction..... 37

Communication Programming

Introduction..... 38
 Serial Port Programming..... 39
 Check..... 40
 Stop Bit..... 41
 Flow Control..... 42
 Data Bit..... 43

Data Format

Introduction..... 45
 Prefix Sequences..... 46
 User Prefix..... 47
 Disable or Enable User Prefix..... 47
 Program User Prefix..... 47





AIM Prefix	48
Code ID Prefix	49
User Suffix	50
Disable or Enable User Suffix	50
Program User Suffix	50
Terminal	51
Disable or Enable Terminal	51
Program Terminal	51

Symbols

Introduction.....	52
Code 128.....	53
Load Factory Default.....	53
Enable/Disable Code 128	53
Code 128 Code ID	53
Select Message Length	54
UCC/EAN-128.....	55
Load Factory Default.....	55
Enable/Disable UCC/EAN-128	55
UCC/EAN-128 Code ID	55
Select Message Length	56
AIM 128.....	57
Load Factory Default.....	57
Enable/Disable AIM 128	57
AIM 128 Code ID	57
Select Message Length	58
EAN-8.....	59
Load Factory Default.....	59
Enable/Disable EAN-8	59
EAN-8 Code ID	59
2 Digits Addenda Code	60
5 Digits Addenda Code	60
EAN-8 expand to EAN-13.....	61
Check Digit.....	61
EAN-13.....	62
Load Factory Default.....	62
Disable/Enable EAN-13	62
Check Digit	63
EAN-13 Code ID	63
2 Digits Addenda Code	64
5 Digits Addenda Code	64
ISSN.....	65
Load Factory Default.....	65
Enable/Disable ISSN	65
ISSN Code ID	65
ISBN	66
Load Factory Default.....	66
Enable/Disable ISBN.....	66





ISBN Digits	67
ISBN Code ID.....	67
UPC-E.....	68
Load Factory Default.....	68
Disable/Enable UPC-E.....	68
Check Digit.....	69
UPC-E Code ID.....	69
2 Digits Addenda Code.....	70
5 Digits Addenda Code.....	70
Transmit Preamble Character	71
UPC-E Expand to UPC-A.....	71
UPC-A.....	72
Load Factory Default.....	72
Disable/Enable UPC-A.....	72
UPC-A Code ID.....	72
Check Digit.....	73
Transmit Preamble Character	73
2 Digits Addenda Code.....	74
5 Digits Addenda Code.....	74
Interleaved 2 of 5.....	75
Load Factory Default.....	75
Disable/Enable Interleaved 2 of 5.....	75
Interleaved 2 of 5 Code ID.....	75
Check Digit.....	76
Select Message Length.....	77
ITF-6.....	78
ITF-6 Code ID.....	78
ITF-14.....	79
ITF-14 Code ID.....	79
Deutsche14.....	80
Load Factory Default.....	80
Disable/Enable Deutsche14.....	80
Deutsche14 Code ID.....	80
Deutsche12.....	81
Load Factory Default.....	81
Disable/Enable Deutsche12.....	81
Deutsche12 Code ID.....	81
COOP25 (Japanese Matrix 2 of 5).....	82
Load Factory Default.....	82
Enable/ Disable COOP25.....	82
COOP25 (Japanese Matrix 2 of 5) Code ID.....	82
Check Digit.....	83
Select Message Length.....	84
Matrix 2 of 5(European Matrix 2 of 5).....	85
Load Factory Default.....	85
Enable/ Disable Matrix 2 of 5.....	85
Matrix 2 of 5 Code ID.....	85
Check Digit.....	86
Select Message Length.....	87



Industrial 25	88
Load Factory Default	88
Enable/ Disable Industrial 25	88
Industrial 25 Code ID	88
Check Digit	89
Select Message Length	90
Standard 25	91
Load Factory Default	91
Enable/ Disable Standard 25	91
Standard 25 Code ID	91
Check Digit	92
Select Message Length	93
Code 39	94
Load Factory Default	94
Enable/Disable Code 39	94
Code 39 Code ID	94
Check Digit	95
Transmit Start & Stop Character	96
Decode ASCII	96
Select Message Length	97
Codabar	98
Load Factory Default	98
Enable/Disable Codabar	98
Codabar Code ID	98
Check Digit	99
Transmit Start & Stop Character	100
Select Message Length	101
Code 93	102
Load Factory Default	102
Enable /Disable Code 93	102
Code 93 Code ID	102
Check Digit	103
Select Message Length	104
Code 11	105
Load Factory Default	105
Enable/ Disable Code 11	105
Code 11 Code ID	105
Check Digit	106
Select Message Length	107
Plessey	108
Load Factory Default	108
Enable/ Disable Plessey	108
Plessey Code ID	108
Check Digit	109
Select Message Length	110
MSI-Plessey	111
Load Factory Default	111
Enable/ Disable MSI-Plessey	111
MSI-Plessey Code ID	111





Check Digit	112
Select Message Length	113
GS1 Databar	114
Load Factory Default	114
Enable/ Disable GS1 Databar	114
GS1 Databar Code ID	114

Appendix

Factory Default List	115
AIM ID List	121
Code ID List	122
Digit Code	123
Save and Abort	125
ASCII Table	126





About this guide

Introduction

This NLS-EM1300 (“EM1300”) Scan Engine Integration Guide provides general instructions for OEM integration.

Chapter Description

About EM1300: The chapter of About EM1300 gives a brief description of the EM1300. It covers the general, overall specifications of the EM1300.

Mechanical Interface: The chapter of Mechanical Interface describes the mechanical interface of the EM1300. It includes the dimensions and locations of EM1300 mechanical components.

Electrical Interface: The chapter of Electrical Interface describes the electrical interface of the EM1300. It mainly explains the EM1300 interface socket and flexible cable. Samples of schematics are also included.

Software Interface: The chapter of Software Interface describes the software interface of EM1300.

EM1300 Development Tools: The chapter of EM1300 Development Tools lists the development tools and brief descriptions of the tools.

Programming the Engine: The chapter of Configuration lists all the configurations of EM1300. The configuration can be done through pre-printed configuration barcodes, serial port commands, and/or Quickset, a Newland software package.

Graphic Notations



Tool – Handy item for a task.



Attention – Important subject to be aware of or to avoid.



Tips – Helpful information about a topic or a feature.



Example – Illustration of how to use a feature.



About this guide

Newland Auto-ID Support Center

If you have a problem with your equipment, contact the Newland Support Center in your region. Before calling, have the model number, serial number, and several of your barcodes at hand.

Call the support Center from a phone near the scanning equipment so that the service person can try to talk you through your problem. If the equipment is found to be working properly and the problem is barcode readability, the Support Center will request samples of your bar codes for analysis at our plant.

If your problem cannot be solved over the phone, you may need to return your equipment for servicing. If that is necessary, you will be given specific directions.

Note: Newland Auto-ID Tech. is not responsible for any damages incurred during shipment.

For service information, warranty information or technical assistance contact or call the Support Center listed below. For the latest service information go to <http://www.nlscan.com/>





About EM1300

Introduction

EM1300 is an embedded barcode reading engine. Its gray scale CCD image capturer and the Newland patented UIMG, a Computerized Image Recognition System, ensure the fast scanning and decoding accuracy on different barcode media such as paper, plastic card, and metal surface. It can be easily integrated into OEM equipments or systems (hand-held, portable, and mounted) to provide solutions for image capture, barcode reading, and barcode message processing.

Highlights of the EM1300

- » Compact design allowing easy integration into OEM equipments and systems.
- » Outstanding decoding performance for major 1D barcodes.
- » High performance CPU ensuring fast and accurate scans.
- » Easy OEM software development and firmware upgrade.





Unpacking

Remove EM1300 and accessories from the package. Check for missing parts and inspect for damage. EM1300 is packed in anti-static bag. Please handle accordingly.



If there is any damage or missing parts, please contact your supplier at once. Keep the original package for return services, if necessary.

Outline of EM1300

The outline of EM1300 is shown in Figure 1. The topside has the electrical control components, including a flexible cable socket, Interface Socket, through which EM1300 interfaces with external device.

The front side has the optical components, such as Image Lens, through which EM1300 captures image, Illumination Light, which sends a linear, red light beam for illuminating and aiming.

The bracket covers the sides and bottom of the Engine. Two mounting holes on the bottom side are available for mounting the Engine to external device.

The back side is CCD circuit for image capture.

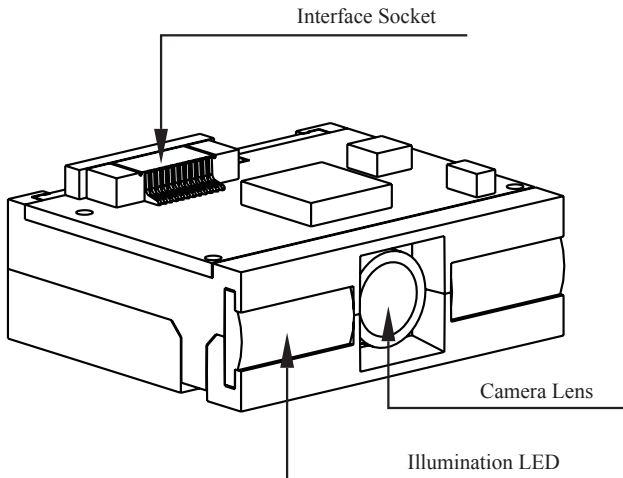

Figure 1. EM1300 Outline



Mechanical Interface

Introduction

This section describes the Mechanical Interface.





EM1300 Front View

Following figures show the dimensions of EM1300. The figure 2 is EM1300 Front View.

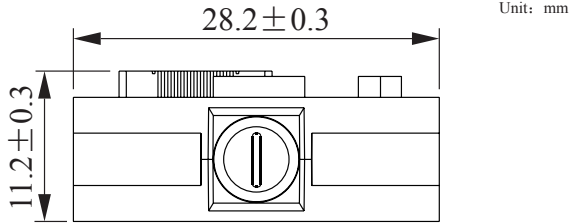

Figure 2. EM1300 Front View

EM1300 Left Side View

The Figure 3 is EM1300 Left Side View.

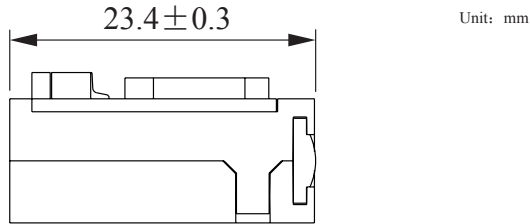

Figure 3. EM1300 Left Side View

EM1300 Bottom View

The figure 4 EM1300 Bottom View has the mounting screw specifications. The mounting screw is M1.4, 1.4mm screw. The length of the screw into EM1300 must be less than 3 mm.

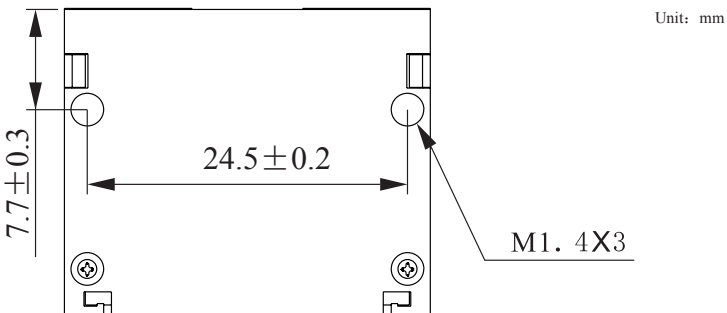

Figure 4. EM1300 Bottom View



Interface Socket

EM1300 uses a 12-pins flex cable socket to interface with external device (Host), such as EVK3000 V2, the EM1300 Evaluation Kit. Figure 5 below shows the socket. For reference purpose, the EM1300 Evaluation Kit uses a connector to connect the flex cable.

Unit: mm

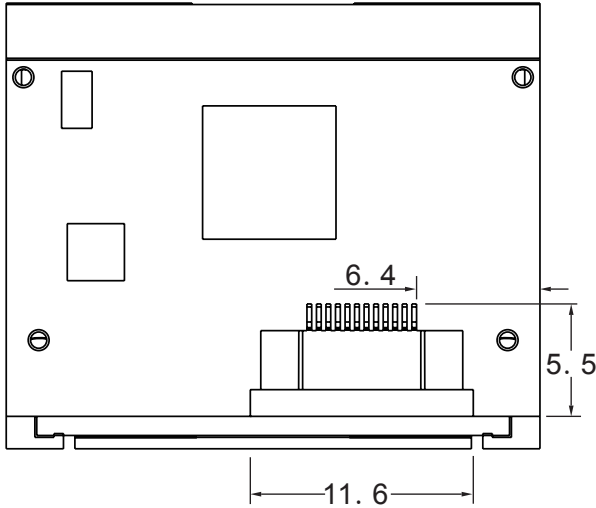
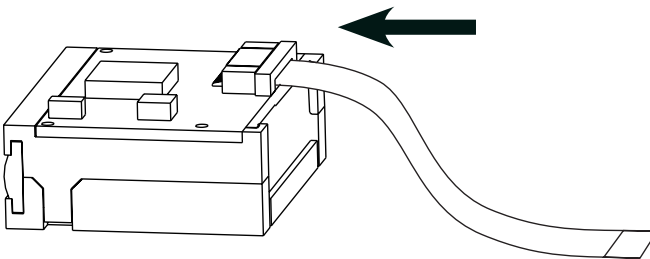

Figure 5. Interface Socket

Interface Cable

A 50 mm flexible cable is included in the EM1300 package. Both of the two ends are 12 PINS. One connects to the EM1300 interface socket, the other connects to external device. Figure below shows how the cable is connected to the interface socket.





Interface Socket Pin Assignment and Definition

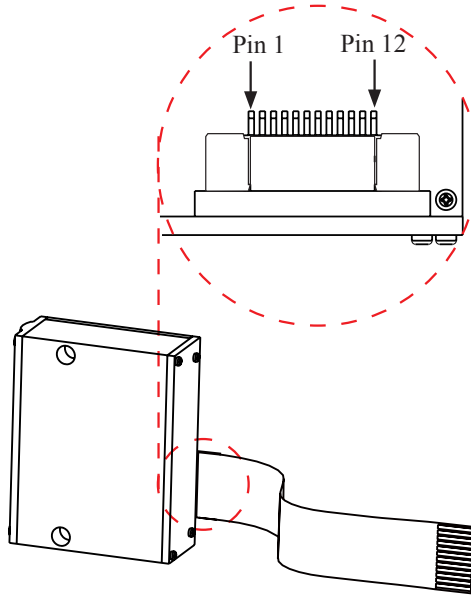

Pin	Type	I/O*	Description
PIN 1	Flash Download	I	Operation Mode Control: » Flash Download Mode – Level Low when engine is powered on; » Normal Mode – otherwise.If users don' t need the function, it can be not connected(N/C).
Pin 2	VCC	P	DC 3.3 ± 0.3V
Pin 3	Ground	GND	Ground
Pin 4	RXD	I	RS232 Receiving, TTL
Pin 5	TXD	O	RS233 Transmission, TTL
Pin 6	Reserved for CTS		Reserved for CTS, not implemented
Pin 7	Reserved for RTS		Reserved for RTS, not implemented
Pin 8	N/C		Not connected
Pin 9	Beeper	O	Beeper output. Need an external current amplifier.
Pin 10	DLED	O	Decode LED. Need an external current amplifier.
Pin 11	N/C		Not connected
Pin 12	Trigger	I	Trigger read and decode

* I/O Definitions: I – Input, O – Output, and P – Power, GND – Ground





Schematic of Interface Socket

Unit: mm

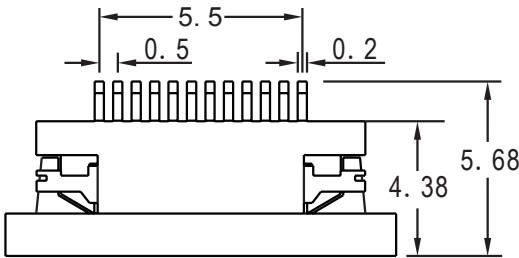
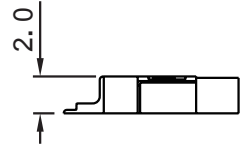
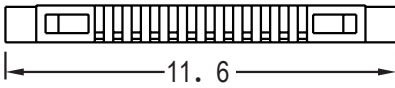



Interface Flexible Cable Specifications

The interface flexible cable is designed by Newland Auto-ID.

Unit: mm

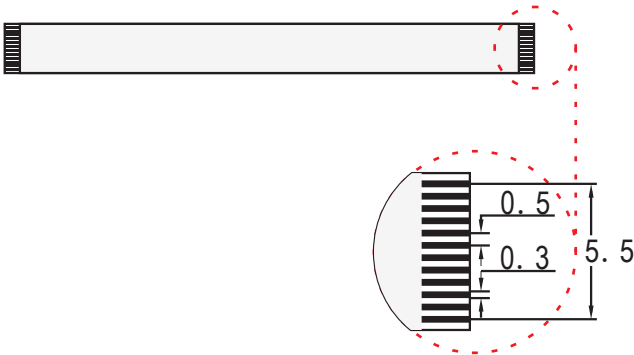
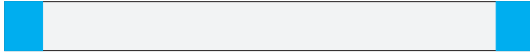



Housing Structure

The housing for the Engine should make sure that no pressure should be put on the Engine. There should have sufficient space for the flexible cable and stress release of the cable should also be considered.

Scan Window

A scan window is needed to protect camera lens and illumination lights. This scan window design should follow:

- » Housing must not block or shade illumination LED' s aiming light, and camera lens.
- » Use high transparent and scratch resistant material.
- » The gap and angle between housing window and illumination LED (highest point) must ensure that the illumination light should not be reflected into lens by window glass.





Electrical Interface

Introduction

This section describes the electrical specifications of the interface signals.





The table below lists the interface input and output level voltage ranges

Signal Type	Voltage Level	Voltage Range
Input	High	2.4V - 3.6V
	Low	-0.3V - 0.6V
Output	High	2.9V - 3.3V
	Low	0V - 0.4V





Trigger Input

When the Trigger line is pull low for 10 ms, the Engine starts a read. The Engine keeps reading until a successful reading, a timeout or the line is high. After a successful reading, the line must go high in order to make another read.

A Sample Schematic of Trigger Input Circuit

Here is a schematic from the evaluation board, EVK3000 V2. The signal can connect to external device's output port.

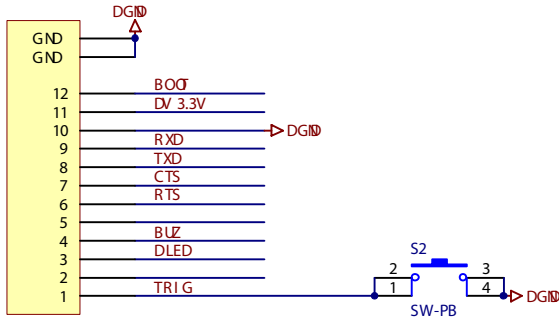



Here are the descriptions of the output signals, such as Beeper, LED and inter-character timeout. They can be used to detect the status of the scanning, message uploading and the state of the Engine.

LED Output

When the Engine completes the initialization, the LED line is high. The LED line goes low for 150 ms after a successful reading and, if programmed, transmission of the code message.

Beeper Output

Table below is the definitions of the beeper outputs:

Beep Pattern	Definition
Low-higher-higher-higher	Power ON completed
1 beep	Successful reading of an ordinary barcode
2 beeps	Successful reading of a programming barcode

Inter-Character Timeout

The message upload format is in binary. It is the binary value of the decoded barcode value including prefix, suffix, and so on.

Inter-Character Timeout is used to determine the end of barcode message.

Host could use inter-character timeout to determine the end of data upload. An inter-character timeout means the longest delay time between 2 consecutive (binary) characters in a sequence of (binary) characters sent over serial line. It is usually enabled only after the first character is received to avoid unwanted timeout events during the waiting of a message.

The inter-character timeout value should be set to about 5 times of a character's transmission time. When the inter-character timeout occurs, it is the end of data upload. For example, 5 ms can be used as an inter-character timeout for the baud rate of 9600, 8 data bit, no parity bit, and one stop bit.





A Sample Schematic of LED Circuit

Here is the LED circuit used in the evaluation board, EVK3000 V2.

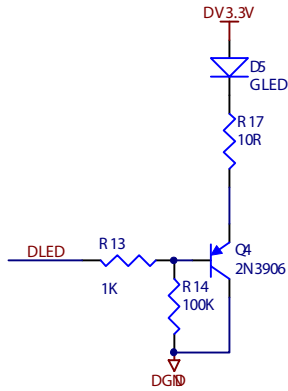

A Sample Schematic of Beeper Circuit

Here is a beeper circuit used in the evaluation board, EVK3000 V2.

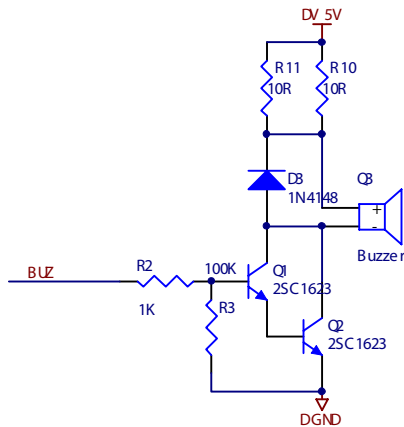



EM1300 Development Tools

Introduction

Sections below list some EM1300 development tools. A brief introduction to each tool is included.





Here is a brief introduction to the EM1300 Evaluation Kit, EVK3000 V2. The layout of the EVK3000 V2 circuit board is shown in figure below. The board contains beeper and trigger button. A USB connector and an alternative RS232 is for communication. The J5 connector is where the EM1300 flex cable connects to.

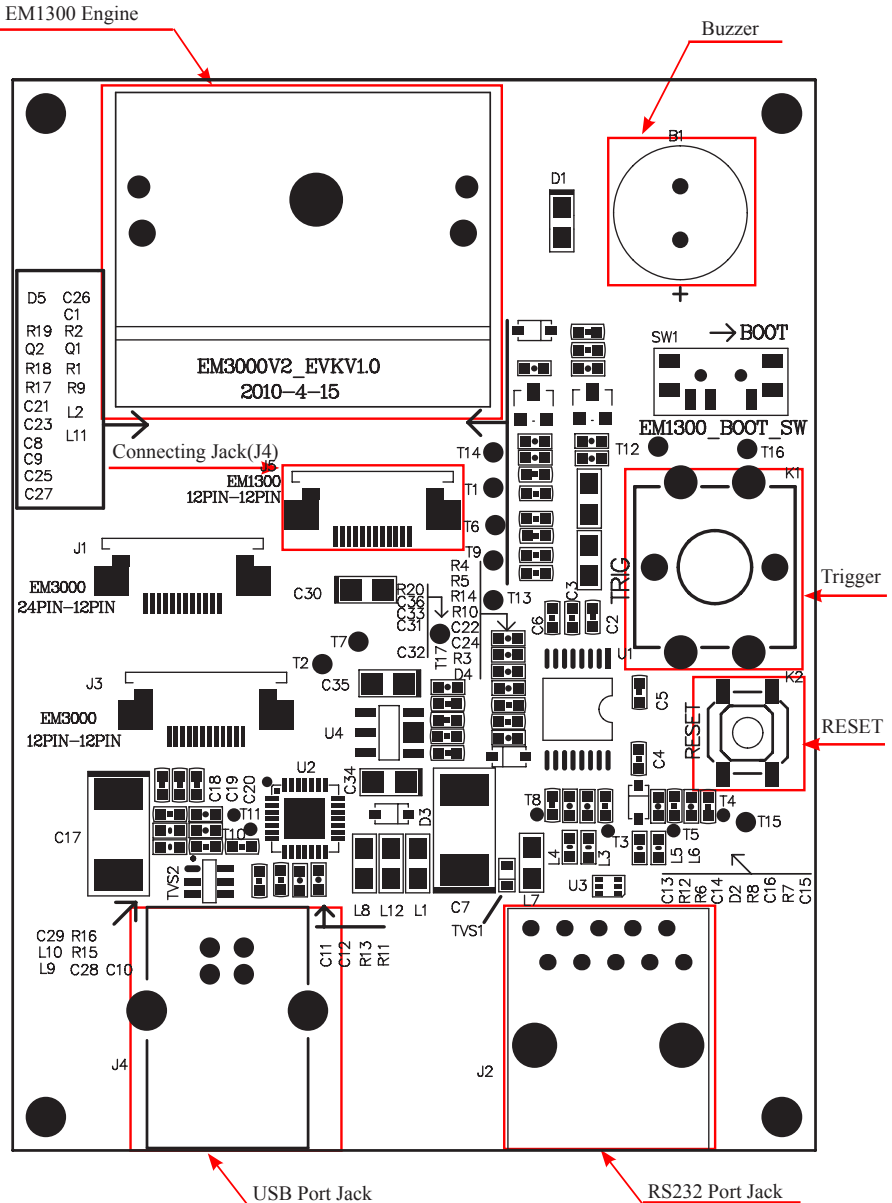



General Programming

Introduction

There are 2 ways to program (configure) the Engine, Code Programming and Command Programming.

Code Programming

The Engine reads a set of specially encoded barcodes to program options and features. In the following sections, we will explain the options and features available and provide the barcodes to program them.

This method of programming the Engine is most straight forward. However, it requires manually readings of each barcode. As all manual operations, errors are more likely to occur.

Command Programming

The Host can send the Pro CMD strings to program the Engine. In the following sections, the Pro CMD strings will be included with the barcodes for Code Programming.

This method of programming the Engine could be automated. A software program can be developed to download all the configuration data to the Engine. The program can also verify the download.

Note: Except some temporary programming, the programming results are restored in non-volatile memory. They will not be lost when the Engine is powered off.





Code Programming ON



Code Programming OFF



This is the notation to disable the Code Programming.

There are 3 parts of a notation:

- 1、 The barcode for Code Programming
- 2、 The name of the options or features, such as Disable Code Programming.
- 3、 The corresponding Pro CMD string of the Code Programming.





Code Programming ON



Code Programming OFF



Read the “Code Programming ON” barcode to activate “Code Programming” function. More than one Code Programming barcodes can be read to configure the Engine.

If an option or feature needs additional parameters, such as digits, they can be found at the end of this chapter.

The value of code programming can be sent to the Host. For factory default, “No Send Pro Code Value”, the value of programming codes will not be sent to the Host; by reading “Send Pro Code Value”, the reader will send the value of Programming Code to the Host.

The factory default setting is “Code Programming ON”. Because it has low probability that a data barcode is the same as a programming barcode, it doesn't need to close the function of Code Programming. Keeping it on won't affect the daily using.

Some working parameters could be programmed. The data type of parameters is Dec or Hex and the numbers are also input through programming barcodes. The Appendix of the Integration Guide includes all needed data barcodes.

Programming barcodes are used to program the engine. For factory default, the reader will not send code value to the Host. But if needed, the engine could be programmed to "Send Pro Code Value". And whether the value is sent or not won't affect the programming function. But "Send Pro Code Value" is a temporary setting. It will restore to "No Send Pro Code Value" when the engine is restarted or closed.



Code Programming ON
【Pro CMD: 99900031】



Code Programming OFF
【Pro CMD: 99900032】



No Send Pro Code Value
【Pro CMD: 99900033】



Send Pro Code Value
【Pro CMD: 99900034】





3、 Flow Chart

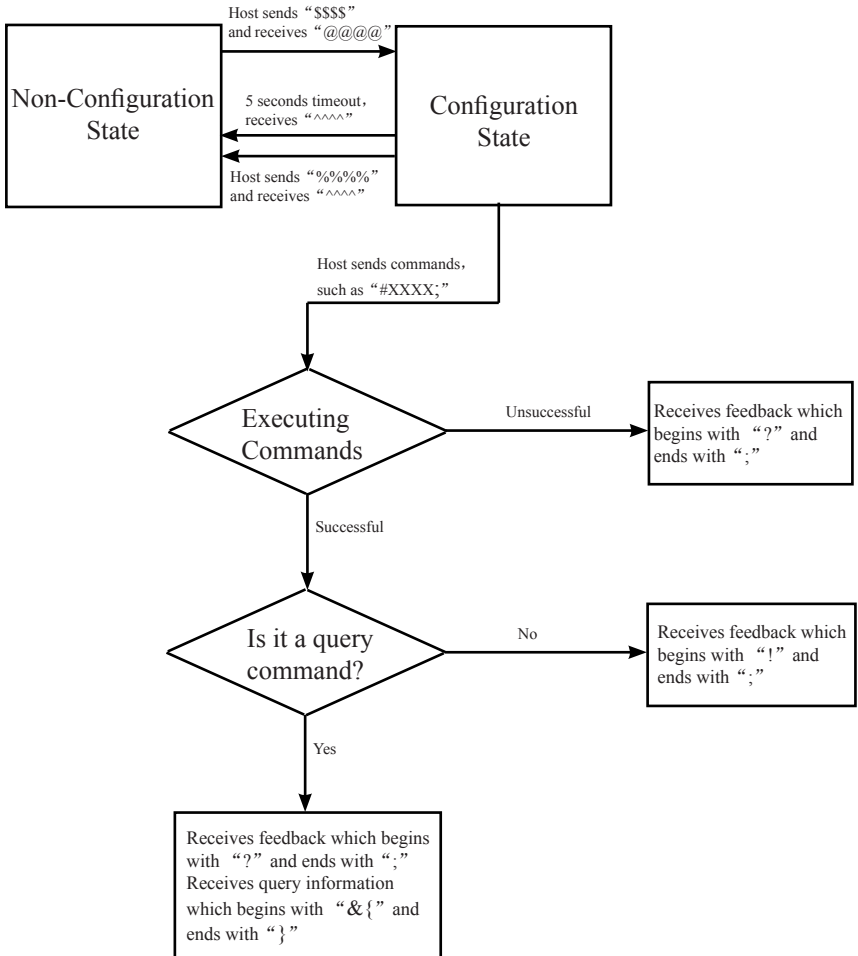



Factory Default

Read “Load All Factory Default” to reset all parameters to factory default.

Applicable conditions:

- » User options programming wrong configuration leads to reading malfunction
- » Forget details of previous programming and start over.
- » Restore to default after unusual settings are not needed.

Code Programming ON



Code Programming OFF



Load All Factory Default
【Pro CMD: 99900030】





Code Programming ON



Code Programming OFF



Shut Down¹

【Pro CMD: 99900100】



Deep Sleep²

【Pro CMD: 99900101】



Sleep³

【Pro CMD: 99900102】



Test Mode⁴

【Pro CMD: 99900103】



Restart

【Pro CMD: 99900104】

Note:

- 1、 The engine couldn't be awaked. It must restart or power on.
- 2、 It should be awaked by a trigger.
- 3、 It could be awaked by communication or a trigger.
- 4、 Use a trigger to quit test mode.



All these five modes are temporary. They will disappear and restore to former mode if the engine restarts or powers off.



Hand-held Mode

Factory Default, scan engine will begin to scan when triggered. And when it scans successfully or the trigger is released, the engine will stop scanning.



Hand-held Mode
【Pro CMD: 99900110】

In hand-held mode, the engine could set Reading a barcode time length.



Reading a barcode time length
【Pro CMD: 99900150】

Auto Sleep allows the engine in hand-held mode to automatically enter the Sleep or Deep Sleep mode if it remains idle (no operation or communication is performed) for a time period (user programmable). When the engine is in the Sleep or Deep Sleep mode, receiving trigger signal can wake it up.



Enable Auto Sleep
【Pro CMD: 99900162】



Disable Auto Sleep
【Pro CMD: 99900163】



Sleep Mode
【Pro CMD: 99900164】



Deep Sleep Mode
【Pro CMD: 99900165】



Idle Timeout
【Pro CMD: 99900166】

The Idle Timeout is programmable in 0.1s increments from 0.0s to 6.0s. Single digit values must have a leading zero.

e.g. Set the idle timeout to 0.5s:

- 1、Read “Code Programming ON”
- 2、Read “Idle Timeout”
- 3、Read numbers “0” “5”
- 4、Read “Code Programming OFF”



Auto Mode

First program the engine, then trigger it, the engine will start to scan. After a scan, the engine will not stop but start a new one automatically until another trigger. By default, the engine will not repeat reading a same barcode.

Code Programming ON



Code Programming OFF



Auto Mode

【Pro CMD: 99900111】

In auto mode, the engine could set Reading a barcode time length, and set if it could read same barcode.



Reading a barcode time length

【Pro CMD: 99900150】



Disable Reading Same Barcode

【Pro CMD: 99900155】



Restart Timer After a Valid Reading

【Pro CMD: 99900157】



Enable Reading Same Barcode

【Pro CMD: 99900156】

» Reading Same Barcode

When enabled, after a successful read, the engine will not stop but start a new one automatically until another trigger.

When disabled, after a successful read, if the next barcode is the same one, the engine will keep waiting. If the next barcode is different, the engine will not stop but start a new one automatically until another trigger.

» Restart Timer After a Valid Reading

When enabled, after a successful read, the engine will revert the reading time to zero and restart timer.





Interval Mode

After programming, the engine will start interval scan without trigger. The interval between two scans is fixed whether the scan is successful or not. The value of interval could be programmed by user and the default value is 1s.

Code Programming ON



Code Programming OFF



Interval Mode

【Pro CMD: 99900112】



Reading a barcode time length

【Pro CMD: 99900150】



Interval Length

【Pro CMD: 99900151】

Interval takes 500ms as a unit and could be classed in fifteen levels:0-15. For instance, interval could be programmed to 5000ms:

- 1、Read “Code Programming ON”
- 2、Read “Interval Length”
- 3、Read numbers “1” “0”
- 4、Read “Code Programming OFF”





Sensor Mode

After programming, the engine will start to sense the environment without trigger. After a scan, it will stop and keep sensing to wait another illumination changing. In sensor mode, a trigger also can start a scan. The sensitivity level could be chosen.

Code Programming ON



Code Programming OFF



Sensor Mode

【Pro CMD: 99900113】

In sensor mode, the engine could set Reading a barcode time length, and set interval length as sensing stabilization time.



Reading a barcode time length

【Pro CMD: 99900150】



Interval Length

【Pro CMD: 99900151】

Sensitivity is used to evaluate the engine's ability to sense the changing environment. Users can choose a sensitivity level which suits the environment.



High Sensitivity

【Pro CMD: 99900152】



Low Sensitivity

【Pro CMD: 99900154】



Medium Sensitivity

【Pro CMD: 99900153】



User Sensitivity

【Pro CMD: 99900161】

Sensitivity Level Programming

There are sixteen levels of 0 to F. The lower the value is, the higher the sensitivity level is.

For instance, we could program sensitivity level as 5 level.

- 1、Read “Code Programming ON”
- 2、Read “User Sensitivity”
- 3、Read number “5”
- 4、Read “Code Programming OFF”





Timeout between Decodes (Same Barcode) can avoid undesired rereading of same barcode in a given period of time.



Timeout between Decodes (Same Barcode)

【Pro CMD: 99900167】

Code Programming ON



Code Programming OFF



Timeout between Decodes (Same Barcode) is programmable in 0.1s increments from 0.0s to 12.0s. If you want to stop the engine from rereading the same barcode, set this parameter to 12.7s. Values less than 100 require one or two leading zeros to make up 3 digits.

e.g. Set the timeout between decodes (same barcode) to 5.0s:

- 1、Read “Code Programming ON”
- 2、Read “Timeout between Decodes (Same Barcode)”
- 3、Read numbers “0” “5” “0”
- 4、Read “Code Programming OFF”





Continuous Mode

After programming, the engine will be in continuous mode without trigger. After a successful scan, the engine will be in waiting state until another scan, then wait again.

Code Programming ON



Code Programming OFF



Continuous Mode

【Pro CMD: 99900114】

In continuous mode, the engine could set interval length.



Interval Length

【Pro CMD: 99900151】

Timeout between Decodes (Same Barcode) can avoid undesired rereading of same barcode in a given period of time.



Timeout between Decodes (Same Barcode)

【Pro CMD: 99900167】

Timeout between Decodes (Same Barcode) is programmable in 0.1s increments from 0.0s to 12.0s. If you want to stop the engine from rereading the same barcode, set this parameter to 12.7s. Values less than 100 require one or two leading zeros to make up 3 digits.

e.g. Set the timeout between decodes (same barcode) to 5.0s:

- 1、Read “Code Programming ON”
- 2、Read “Timeout between Decodes (Same Barcode)”
- 3、Read numbers “0” “5” “0”
- 4、Read “Code Programming OFF”





Delayed Sensor Mode

After programming, the engine will start to sense the environment without trigger. There will be a delay before a scan. After a scan, it will stop and keep sensing to wait another illumination changing. In delayed sensor mode, a trigger also can start a scan. The sensitivity level could be chosen.

Code Programming ON



Code Programming OFF



Delayed Sensor Mode
【Pro CMD: 99900115】

In delayed sensor mode, the engine could set Reading a barcode time length and interval length.



Reading a barcode time length
【Pro CMD: 99900150】



Interval Length
【Pro CMD: 99900151】



In delayed sensor mode, reading a barcode time takes 2s as a unit and the range is from 0 to 30ms, 0 is infinite time; Interval takes 200ms as unit and the range is from 0 to 7.5s.



Command Triggered Mode

After programming, when the engine receives trigger sweep command from terminal (e.g. PC) or read "Start Analog Trigger" barcode, the engine will start to work.

PS: If reading is successful, data will be returned and the engine wil stop working automatically. Or the engine will keep reading until receiving stop command or reading "Stop Analog Trigger" .

When the engine receives stop command from terminal (e.g. PC) or read "Stop Analog Trigger" barcode, the engine will stop. Meanwhile a 2 byte data(e.g. 0A;0X) must be returned.

Code Programming ON



Code Programming OFF



Command Triggered Mode
【Pro CMD: 99900116】



Start Analog Trigger
【Pro CMD: 99900035】



Stop Analog Trigger
【Pro CMD: 99900036】

If a reading is failed, the engine will send a character which means a reading failure. Users could set the character themselves.



Set Reading Failure Character
【Pro CMD: 99904200】





The higher the value of Security Level is, the lower the probability of mis-decoding and the decoding speed are. Otherwise, the speed is higher.

Code Programming ON



Code Programming OFF



Security Level 1

【Pro CMD: 99900120】



Security Level 3

【Pro CMD: 99900122】



Security Level 2

【Pro CMD: 99900121】



Security Level 4

【Pro CMD: 99900123】





No Beeper Output
【Pro CMD: 99900130】



High Frequency & Loud Volume
【Pro CMD: 99900131】



High Frequency & Medium Volume
【Pro CMD: 99900132】



High Frequency & Low Volume
【Pro CMD: 99900133】



Medium Frequency & Loud Volume
【Pro CMD: 99900134】



Medium Frequency & Medium Volume
【Pro CMD: 99900135】



Medium Frequency & Low Volume
【Pro CMD: 99900136】

Code Programming ON



Code Programming OFF



Low Frequency & Loud Volume
【Pro CMD: 99900137】



Low Frequency & Medium Volume
【Pro CMD: 99900140】



Low Frequency & Low Volume
【Pro CMD: 99900141】



150ms Sound Length
【Pro CMD: 99900142】



100ms Sound Length
【Pro CMD: 99900143】



50ms Sound Length
【Pro CMD: 99900144】





Start/Stop Temporary Mute

Code Programming ON



Code Programming OFF



Start Temporary Mute
【Pro CMD: 99900040】



Stop Temporary Mute
【Pro CMD: 99900041】





Query Command

Introduction

After reading interrelated programming barcodes, the engine will feed information needed back to the Host to achieve the purpose of query.



Code Programming ON



Code Programming OFF



Query Product Information
【Pro CMD: 99900300】



Query Manufacturing Date
【Pro CMD: 99900303】



Query Hardware Version
【Pro CMD: 99900301】



Query Product Name
【Pro CMD: 99900304】



Query Product ID
【Pro CMD: 99900302】



Communication Programming

Introduction

Under TTL232 connection the engine and the Host use the same communication parameters: baud rate, parity check, data bits select and stop bits select.





Under TTL232 connection, the engine and the Host should set communication baud rate to the same to keep normal communication.
Baud rate is the bits transmitted per second (8 bits per bytes). The engine and the Host must communicate at the same baud rate.
The reader supports baud rate as the following:

Code Programming ON



Code Programming OFF



** 9600

【Pro CMD: 99902104】



2400

【Pro CMD: 99902102】



14400

【Pro CMD: 99902105】



38400

【Pro CMD: 99902107】



115200

【Pro CMD: 99902111】



1200

【Pro CMD: 99902101】



4800

【Pro CMD: 99902103】



19200

【Pro CMD: 99902106】



57600

【Pro CMD: 99902110】





Check

Code Programming ON



Code Programming OFF



** No Check

【Pro CMD: 99902120】



Even Check

【Pro CMD: 99902122】



Odd Check

【Pro CMD: 99902121】





Stop Bit

Code Programming ON



Code Programming OFF



** 1 Stop Bit

【Pro CMD: 99902131】



2 Stop Bit

【Pro CMD: 99902133】





Flow Control

Code Programming ON



Code Programming OFF



** No Flow Control
【Pro CMD: 99902140】





Data Bit

Code Programming ON



Code Programming OFF



** 8 Data Bit

【Pro CMD: 99902150】



8 Data Bit, No Check, 2 Stop Bit

【Pro CMD: 99902163】



8 Data Bit, No Check, 1 Stop Bit

【Pro CMD: 99902160】



8 Data Bit, Even Check, 2 Stop Bit

【Pro CMD: 99902164】



8 Data Bit, Even Check, 1 Stop Bit

【Pro CMD: 99902161】



8 Data Bit, Odd Check, 2 Stop Bit

【Pro CMD: 99902165】



8 Data Bit, Odd Check, 1 Stop Bit

【Pro CMD: 99902162】





Code Programming ON



Code Programming OFF



7 Data Bit

【Pro CMD: 99902151】



7 Data Bit, Even Check, 2 Stop Bit

【Pro CMD: 99902170】



7 Data Bit, Even Check, 1 Stop Bit

【Pro CMD: 99902166】



7 Data Bit, Odd Check, 2 Stop Bit

【Pro CMD: 99902171】



7 Data Bit, Odd Check, 1 Stop Bit

【Pro CMD: 99902167】





Data Format

Introduction

1D barcodes could contain digits, letters and symbols, etc. 2D barcodes could contain more data, such as Chinese characters and other multi-byte characters. However, in reality, they do not and should not have enough information we need, such as barcode type, date and time of scan, delimiter, and so on, in order to keep the code short and flexible.

Prefix and Suffix are how to fulfill the needs mentioned above. They can be added, removed, and modified while the original barcode message is still in tact.



Barcode processing sequences: first add Prefix/Suffix, then terminate with
Terminal and transmit.



Code Programming ON



Code Programming OFF



CodeID+User Prefix+AIMID
【Pro CMD: 99904010】



User Prefix+CodeID+AIMID
【Pro CMD: 99904011】





Disable or Enable User Prefix

User Prefix is added before barcode message. For example, if the user prefix is “AB” and the barcode message is “123” , the Host receives “AB123” .

Code Programming ON



Code Programming OFF



Disable User Prefix
【Pro CMD: 99904020】



Enable User Prefix
【Pro CMD: 99904021】

Program User Prefix

Enable “Program User Prefix” . Then program user prefix byte(s). To end the prefix, read “Save programming” The user prefix byte is programmed in its hex values. See example below.



Program User Prefix
【Pro CMD: 99904022】

Example

-
- Program “CODE” as user prefix (The hex of “CODE” are 0x43/0x4F/0x44/0x45):
1. Read “Code Programming ON”
 2. Read “Program User Prefix”
 3. Read “4,3,4,F,4,4,4,5” in order
 4. Read “Save Programming”
 5. Read “Code Programming OFF”

If User Prefix is enabled, after finishing the above configuration, “CODE” will be added before scanned data.





AIM (Automatic Identification Manufactures) defines AIM prefix for many standard barcode formats. The engine will add the identifier before the barcodes. And this identifier is the AIM Prefix. And please see Appendix to find the AIM ID list.

Code Programming ON



Code Programming OFF



Disable AIM Prefix for All Barcodes

【Pro CMD: 99904030】



Enable AIM Prefix for All Barcodes

【Pro CMD: 99904031】





Besides AIM prefix, Code ID prefix can be used to denote barcode format and can be customized.

The Code ID prefix **MUST** be one (1) or two(2) visible English letters, capital or small, only.

Code Programming ON



Code Programming OFF



No Code ID Prefix

【Pro CMD: 99904040】



Allow Code ID Prefix

【Pro CMD: 99904041】



Load Code ID Factory Default

【Pro CMD: 99904042】





Disable or Enable User Suffix

User suffix is appended to the right of barcode message. For example, if user suffix is “AB” , and the barcode message is “123” , The Host receives “123AB” .

Code Programming ON



Code Programming OFF



Disable User Suffix
【Pro CMD: 99904100】



Enable User Suffix
【Pro CMD: 99904101】

Program User Suffix

Read “Program User Suffix” . Then program user suffix byte(s). To end the suffix, read “Save programming” . The user suffix byte is programmed in its hex values. See example below.



Program User Suffix
【Pro CMD: 99904102】

Example

Program “AGE” as user suffix (The hex of “AGE” are 0x41/0x47/0x45):

1. Read “Code Programming ON”
2. Read “Program User Suffix”
3. Read “4,1,4,7,4,5” in order
4. Read “Save Programming”
5. Read “Code Programming OFF”

If User Suffix is enabled, after finishing the above configuration, “AGE” will be added after scanned data.





Disable or Enable Terminal

“Terminal” is the termination for a string of barcode messages. It is fixed to the right and the very end of a barcode transmission. The major difference between "Terminal" and "User Suffix" is that the information and the decoded messages in user suffix could be formatted but couldn't in terminal.

Code Programming ON



Code Programming OFF



Disable Terminal
【Pro CMD: 99904110】



Enable Terminal
【Pro CMD: 99904111】

Program Terminal

Read “Program Terminal” . Then program terminal byte(s). At last, read “Save programming” . The terminal byte is programmed in its hex values. See example below.

You can also quickly set terminal to 0x0D or 0x0D,0x0A and enable it by scanning “Set Terminal as 0x0D and Enable Sending” or “Set Terminal as 0x0D,0x0A and Enable Sending” .



Program Terminal
【Pro CMD: 99904112】



Set Terminal as 0x0D and Enable Sending
【Pro CMD: 99904113】



Set Terminal as 0x0D,0x0A and Enable Sending
【Pro CMD: 99904114】

E
xample

-
- Set the terminal to 0x0A (Line Feed)
1. Read “Code Programming ON”
 2. Read “Program Terminal”
 3. Read “0” “A”
 4. Read “Save Programming”
 5. Read “Code Programming OFF”

If Terminal is enabled, after finishing the above configuration an LF character will be added after scanned data.





Symbols

Introduction

Every symbology (barcode type) has its own unique attributes. This chapter provides programming barcodes for configuring the engine so that it can identify various barcode symbologies. The more symbologies are enabled, the slower the engine decodes. It is recommended to disable those that are rarely used to improve the performance of the engine.

The user can scan the appropriate barcode below to enable or disable all barcode types. If all symbologies are disabled, the engine can only identify the programming barcodes.



Enable All Symbologies
【Pro CMD: 99900042】



Disable All Symbologies
【Pro CMD: 99900043】





Load Factory Default



Load Code 128 Factory Default
【Pro CMD: 99910000】

Code Programming ON



Code Programming OFF



Enable/Disable Code 128



Enable Code 128
【Pro CMD: 99910002】



Disable Code 128
【Pro CMD: 99910001】



When the engine can not read Code 128, please read “Enable Code 128” and try again.

Code 128 Code ID



Code ID Setting
【Pro CMD: 99910005】

E
Example

Example of setting Code 128 Code ID to “p” (0x70)

1. Read Enable Code Programming barcode.
2. Read Code 128 Code ID Setting barcode.
3. Read Following Barcodes: “7” , and “0”
4. Read Save barcode
5. Read Disable Code Programming barcode.





Select Message Length

It is used to program the valid reading length of Code 128. The engine will send an error beep, if the decoded data length does not match the valid length.

Code 128 Message Length is defined by “Min. Message Length” and “Max. Message Length” .

Code Programming ON



Code Programming OFF



Min Message Length
【Pro CMD: 99910003】



Max Message Length
【Pro CMD: 99910004】



1D bar code Message Length should not exceed 255 bytes. If Max Message Length is less than Min Message Length, it means the engine will only support barcodes of the two lengths. If Max Message Length is equal to Min Message Length, the engine will only support barcodes of the length.

Example

To set Min Message Length of Code 128 to 8 bytes and Max Message Length to 12 bytes, read these programming codes

- 1、 “Code Programming ON”
- 2、 “Select Min Message Length”
- 3、 Digit Code “8” , see Digit Code
- 4、 “Save Programming” , see Digit Code
- 5、 “Select Max Message Length”
- 6、 Digit Code “1”
- 7、 Digit Code “2”
- 8、 “Save Programming”
- 9、 “Code Programming OFF”





Load Factory Default



Load UCC/EAN-128 Factory Default
【Pro CMD: 99910100】

Code Programming ON



Code Programming OFF



Enable/Disable UCC/EAN-128



Enable UCC/EAN-128
【Pro CMD: 99910102】



Disable UCC/EAN-128
【Pro CMD: 99910101】



When the engine can not read UCC/EAN-128, please read “Enable UCC/EAN-128” and try again.

UCC/EAN-128 Code ID



Code ID Setting
【Pro CMD: 99910105】

E
example

Example of setting UCC/EAN-128 Code ID to “p” (0x70)

1. Read Enable Code Programming barcode.
2. Read UCC/EAN-128 Code ID Setting barcode.
3. Read Following Barcodes: “7” , and “0”
4. Read Save barcode
5. Read Disable Code Programming barcode.





Select Message Length

It is used to program the valid reading length of UCC/EAN-128. The engine will send an error beep, if the decoded data length does not match the valid length.

UCC/EAN-128 Message Length is defined by “Min. Message Length” and “Max. Message Length” .

Code Programming ON



Code Programming OFF



Min Message Length
【Pro CMD: 99910103】



Max Message Length
【Pro CMD: 99910104】



1D bar code Message Length should not exceed 255 bytes. If Max Message Length is less than Min Message Length, it means the engine will only support barcodes of the two lengths. If Max Message Length is equal to Min Message Length, the engine will only support barcodes of the length.

Example

To set Min Message Length of UCC/EAN-128 to 8 bytes and Max Message Length to 12 bytes, read these programming codes

- 1、 “Code Programming ON”
- 2、 “Select Min Message Length”
- 3、 Digit Code “8” , see Digit Code
- 4、 “Save Programming” , see Digit Code
- 5、 “Select Max Message Length”
- 6、 Digit Code “1”
- 7、 Digit Code “2”
- 8、 “Save Programming”
- 9、 “Code Programming OFF”



Load Factory Default



Load AIM 128 Factory Default
【Pro CMD: 99910200】

Code Programming ON



Code Programming OFF



Enable/Disable AIM 128



Enable AIM 128
【Pro CMD: 99910202】



Disable AIM 128
【Pro CMD: 99910201】



When the engine can not read AIM 128, please read “Enable AIM 128” and try again.

AIM 128 Code ID



Code ID Setting
【Pro CMD: 99910205】

E
example

- Example of setting AIM 128 Code ID to “p” (0x70)
1. Read Enable Code Programming barcode.
 2. Read AIM 128 Code ID Setting barcode.
 3. Read Following Barcodes: “7” , and “0”
 4. Read Save barcode
 5. Read Disable Code Programming barcode.



Select Message Length

It is used to program the valid reading length of AIM 128. The engine will send an error beep, if the decoded data length does not match the valid length.

AIM 128 Message Length is defined by “Min. Message Length” and “Max. Message Length” .

Code Programming ON



Code Programming OFF



Min Message Length
【Pro CMD: 99910203】



Max Message Length
【Pro CMD: 99910204】



1D bar code Message Length should not exceed 255 bytes. If Max Message Length is less than Min Message Length, it means the engine will only support barcodes of the two lengths. If Max Message Length is equal to Min Message Length, the engine will only support barcodes of the length.

Example

To set Min Message Length of AIM 128 to 8 bytes and Max Message Length to 12 bytes, read these programming codes

- 1、 “Code Programming ON”
- 2、 “Select Min Message Length”
- 3、 Digit Code “8” , see Digit Code
- 4、 “Save Programming” , see Digit Code
- 5、 “Select Max Message Length”
- 6、 Digit Code “1”
- 7、 Digit Code “2”
- 8、 “Save Programming”
- 9、 “Code Programming OFF”



Load Factory Default



Load EAN-8 Factory Default
【Pro CMD: 99910400】

Code Programming ON



Code Programming OFF



Enable/Disable EAN-8



Enable EAN-8
【Pro CMD: 9991402】



Disable EAN-8
【Pro CMD: 99910401】



When the engine can not read EAN-8, please read “Enable EAN-8” and try again.

EAN-8 Code ID



Code ID Setting
【Pro CMD: 99910416】

E
example

Example of setting EAN-8 Code ID to “p” (0x70)

1. Read Enable Code Programming barcode.
2. Read EAN-8 Code ID Setting barcode.
3. Read Following Barcodes: “7” , and “0”
4. Read Save barcode
5. Read Disable Code Programming barcode.





2 Digits Addenda Code

2 Digits Addenda Code is the one to the right of an ordinary code.



Disable 2 Digits Addenda Code
【Pro CMD: 99910405】

Code Programming ON



Code Programming OFF



Only Read With 2 digits Addenda Code
【Pro CMD: 99910407】



Enable 2 Digits Addenda Code
【Pro CMD: 99910406】

5 Digits Addenda Code

5 Digits Addenda Code is the one to the right of an ordinary code.



Disable 5 Digits Addenda Code
【Pro CMD: 99910410】



Only Read With 5 digits Addenda Code
【Pro CMD: 99910412】



Enable 5 Digits Addenda Code
【Pro CMD: 99910411】



“ Enable 2 Digits Addenda Code “ — read an ordinary code and 2 digits Addenda Code.
“ Disable 2 Digits Addenda Code “ — read an ordinary code only, and ignore 2 digits Addenda Code.
“ Only Read With 2 digits Addenda Code “ — read 2 digits Addenda Code and only read code with 2 digits Addenda Code.



EAN-8 expand to EAN-13

“ Do Not Expand to EAN-13 “ — keep original type and digits, do not expand.

“ Expand to EAN-13 by Adding Leading 0s “ — expand to EAN-13 but keep code type.

“ Expand Message and Convert to EAN-13 “ — expand code digits and convert code type.

Code Programming ON



Code Programming OFF



Do Not Expand to EAN-13
【Pro CMD: 99910413】



Expand Message and Convert to EAN-13
【Pro CMD: 99910415】



Expand to EAN-13 by Adding Leading 0s
【Pro CMD: 99910414】

Check Digit

EAN-8 is fixed 8 digits barcode and the last digit is check digit. Check digit is a value calculated from all digits. It is used for checking if the all 8 digits are right.



Transmit Check
【Pro CMD: 99910404】



Do Not Transmit Check
【Pro CMD: 99910403】





Load Factory Default

Code Programming ON



Code Programming OFF



Load EAN-13 Factory Default

【Pro CMD: 99910500】

Disable/Enable EAN-13



Enable EAN-13

【Pro CMD: 99910502】



Disable EAN-13

【Pro CMD: 99910501】



When the engine can not read EAN-13, please read “Enable EAN-13” and try again.





Check Digit

Code Programming ON



EAN-13 is fixed 13 digits barcode and the last digit is check digit. Check digit is a value calculated from all digits. It is used for checking if the all 13 digits are right.



Transmit Check

【Pro CMD: 99910504】



Do Not Transmit Check

【Pro CMD: 99910503】

EAN-13 Code ID



Code ID Setting

【Pro CMD: 99910513】

Example

Example of setting EAN-13 Code ID to “p” (0x70)

1. Read Enable Code Programming barcode.
2. Read EAN-13 Code ID Setting barcode.
3. Read Following Barcodes: “7” , and “0”
4. Read Save barcode
5. Read Disable Code Programming barcode.





2 Digits Addenda Code

2 Digits Addenda Code is the one to the right of an ordinary code.



Disable 2 Digits Addenda Code

【Pro CMD: 99910505】



Only Read With 2 digits Addenda Code

【Pro CMD: 99910507】



Enable 2 Digits Addenda Code

【Pro CMD: 99910506】

Code Programming ON



Code Programming OFF



5 Digits Addenda Code

5 Digits Addenda Code is the one to the right of an ordinary code.



Disable 5 Digits Addenda Code

【Pro CMD: 99910510】



Only Read With 5 digits Addenda Code

【Pro CMD: 99910512】



Enable 5 Digits Addenda Code

【Pro CMD: 99910511】



“ Enable 2 Digits Addenda Code “ — read an ordinary code and 2 digits Addenda Code.
“ Disable 2 Digits Addenda Code “ — read an ordinary code only, and ignore 2 digits Addenda Code.
“ Only Read With 2 digits Addenda Code “ — read 2 digits Addenda Code and only read code with 2 digits Addenda Code.



Load Factory Default



Load ISSN Factory Default
【Pro CMD: 99910600】

Code Programming ON



Code Programming OFF



Enable/Disable ISSN



Enable ISSN
【Pro CMD: 99910602】



Disable ISSN
【Pro CMD: 99910601】



When the engine can not read ISSN, please read “Enable ISSN” and try again.

ISSN Code ID



Code ID Setting
【Pro CMD: 99910603】

E xample

Example of setting ISSN Code ID to “p” (0x70)

1. Read Enable Code Programming barcode.
2. Read ISSN Code ID Setting barcode.
3. Read Following Barcodes: “7” , and “0”
4. Read Save barcode
5. Read Disable Code Programming barcode.





Load Factory Default



Load ISBN Factory Default
【Pro CMD: 99910700】

Code Programming ON



Code Programming OFF



Enable/Disable ISBN



Enable ISBN
【Pro CMD: 99910702】



Disable ISBN
【Pro CMD: 99910701】



When the engine can not read ISBN, please read “Enable ISBN” and try again.



ISBN Digits



Use 13 Digits

【Pro CMD: 99910704】

Code Programming ON



Code Programming OFF



Use 10 Digits

【Pro CMD: 99910703】

ISBN Code ID



Code ID Setting

【Pro CMD: 99910705】

E
xample

Example of setting ISBN Code ID to “p” (0x70)

1. Read Enable Code Programming barcode.
2. Read ISBN Code ID Setting barcode.
3. Read Following Barcodes: “7” , and “0”
4. Read Save barcode
5. Read Disable Code Programming barcode.





Load Factory Default



Load UPC-E Factory Default

【Pro CMD: 99911000】

Code Programming ON



Code Programming OFF



Disable/Enable UPC-E



Enable UPC-E

【Pro CMD: 99911002】



Disable UPC-E

【Pro CMD: 99911001】



When the engine can not read UPC-E, please read “Enable UPC-E” and try again.





Check Digit

UPC-E is fixed 8 digits barcode and the last digit is check digit. Check digit is a value calculated from all digits. It is used for checking if the all 8 digits are right.

Code Programming ON



Code Programming OFF



Transmit Check

【Pro CMD: 99911004】



Do Not Transmit Check

【Pro CMD: 99911003】

UPC-E Code ID



Code ID Setting

【Pro CMD: 99911020】

E

example

Example of setting UPC-E Code ID to “p” (0x70)

1. Read Enable Code Programming barcode.
2. Read UPC-E Code ID Setting barcode.
3. Read Following Barcodes: “7” , and “0”
4. Read Save barcode
5. Read Disable Code Programming barcode.





2 Digits Addenda Code

2 Digits Addenda Code is the one to the right of an ordinary code.



Disable 2 Digits Addenda
【Pro CMD: 99911005】



Only Read With 2 digits Addenda Code
【Pro CMD: 99911007】



Enable 2 Digits Addenda Code
【Pro CMD: 99911006】

Code Programming ON



Code Programming OFF



5 Digits Addenda Code

5 Digits Addenda Code is the one to the right of an ordinary code.



Disable 5 Digits Addenda Code
【Pro CMD: 99911010】



Only Read With 5 digits Addenda Code
【Pro CMD: 99911012】



Enable 5 Digits Addenda Code
【Pro CMD: 99911011】



“ Enable 2 Digits Addenda Code “ — read an ordinary code and 2 digits Addenda Code.
“ Disable 2 Digits Addenda Code “ — read an ordinary code only, and ignore 2 digits Addenda Code.
“ Only Read With 2 digits Addenda Code “ — read 2 digits Addenda Code and only read code with 2 digits Addenda Code.



Transmit Preamble Character

Preamble characters (Country Code and System Character) can be transmitted as part of a UPC-E barcode. Select one of the following options for transmitting UPC-E preamble to the host device: transmit system character only, transmit system character and country code (“0” for USA), or transmit no preamble.

Code Programming ON



Code Programming OFF



No Preamble

【Pro CMD: 99911023】



System Character

【Pro CMD: 99911024】



System Character & Country Code

【Pro CMD: 99911025】

UPC-E Expand to UPC-A

“ Do Not Expand “ — keep original type and digits, do not expand.

“Expand to UPC-A “ — expand to UPC-A but keep code type.

“ Expand Message and Convert to UPC-A “ — expand code digits and convert code type.



Do Not Expand

【Pro CMD: 99911015】



Expand Message and Convert to UPC-A

【Pro CMD: 99911017】



Expand to UPC-A

【Pro CMD: 99911016】





Load Factory Default



Load UPC-A Factory Default
【Pro CMD: 99911100】

Code Programming ON



Code Programming OFF



Disable/Enable UPC-A



Enable UPC-A
【Pro CMD: 99911102】



Disable UPC-A
【Pro CMD: 99911101】



When the engine can not read UPC-A, please read “Enable UPC-A” and try again.

UPC-A Code ID



Code ID Setting
【Pro CMD: 99911115】

E xample

Example of setting UPC-A Code ID to “p” (0x70)

1. Read Enable Code Programming barcode.
2. Read UPC-A Code ID Setting barcode.
3. Read Following Barcodes: “7” , and “0”
4. Read Save barcode
5. Read Disable Code Programming barcode.





Check Digit

Code Programming ON



UPC-A is fixed 13 digits barcode and the last digit is check digit. Check digit is a value calculated from all digits. It is used for checking if the all 13 digits are right.

Code Programming OFF



Transmit Check

【Pro CMD: 99911104】



Do Not Transmit Check

【Pro CMD: 99911103】

Transmit Preamble Character

Preamble characters (Country Code and System Character) can be transmitted as part of a UPC-A barcode. Select one of the following options for transmitting UPC-A preamble to the host device: transmit system character only, transmit system character and country code (“0” for USA), or transmit no preamble.



No Preamble

【Pro CMD: 99911120】



System Character

【Pro CMD: 99911121】



System Character & Country Code

【Pro CMD: 99911122】





2 Digits Addenda Code

2 Digits Addenda Code is the one to the right of an ordinary code.



Disable 2 Digits Addenda Code
【Pro CMD: 99911105】

Code Programming ON



Code Programming OFF



Only Read With 2 digits Addenda Code
【Pro CMD: 99911107】



Enable 2 Digits Addenda Code
【Pro CMD: 99911106】

5 Digits Addenda Code

5 Digits Addenda Code is the one to the right of an ordinary code.



Disable 5 Digits Addenda Code
【Pro CMD: 99911110】



Only Read With 5 digits Addenda Code
【Pro CMD: 99911112】



Enable 5 Digits Addenda Code
【Pro CMD: 99911111】



“ Enable 2 Digits Addenda Code ” — read an ordinary code and 2 digits Addenda Code.
“ Disable 2 Digits Addenda Code ” — read an ordinary code only, and ignore 2 digits Addenda Code.
“ Only Read With 2 digits Addenda Code ” — read 2 digits Addenda Code and only read code with 2 digits Addenda Code.



Load Factory Default



Load Interleaved 2 of 5 Factory Default
【Pro CMD: 99911200】

Code Programming ON



Code Programming OFF



Disable/Enable Interleaved 2 of 5



Enable Interleaved 2 of 5
【Pro CMD: 99911202】



Disable Interleaved 2 of 5
【Pro CMD: 99911201】



When the engine can not read Interleaved 2 of 5, please read “Enable Interleaved 2 of 5”
and try again

Interleaved 2 of 5 Code ID



Code ID Setting
【Pro CMD: 99911210】

E
Example

Example of setting Interleaved 2 of 5 Code ID to “p” (0x70)

1. Read Enable Code Programming barcode.
2. Read Interleaved 2 of 5 Code ID Setting barcode.
3. Read Following Barcodes: “7” , and “0”
4. Read Save barcode
5. Read Disable Code Programming barcode.





Check Digit

Interleaved 2 of 5 may include Check Digit (not compulsory) following its barcode messages. If included, it could be the last digit. It verifies the barcode message.

- » “NO Check, Transmit All” means to read without check and transmit all bytes including barcode message and Check digit.
- » “Check, Do Not Transmit Check Digit” means to read and check. If verification is successful, transmit barcode message; if not, engine sends an error beep.
- » “Check, Transmit All” means to read and check. If verification is successful, transmit all messages; if not, engine sends an error beep.

Code Programming ON



Code Programming OFF



“NO Check, Transmit All”
【Pro CMD: 99911203】



Check, Do Not Transmit Check Digit
【Pro CMD: 99911204】



Check, Transmit All
【Pro CMD: 99911205】



When “Check, Do Not Transmit Check digit” is enabled and barcode message length minus one is less than Min Message Length, it will lead to error beep.
E.g.: Reading a 4-byte (include check Digit) Interleaved 2 of 5 with the Min Message Length being 4 bytes and “Check, Do Not Transmit Check digit” enabled leads to error beep.



Code Programming ON

Select Message Length



It is used to program the valid reading length of Interleaved 2 of 5. The engine will send an error beep, if the decoded data length does not match the valid length.



Interleaved 2 of 5 Message Length is defined by “Min. Message Length” and “Max. Message Length”



Min Message Length
【Pro CMD: 99911206】



Max Message Length
【Pro CMD: 99911207】



1D bar code Message Length should not exceed 255 bytes. If Max Message Length is less than Min Message Length, it means the engine will only support barcodes of the two lengths. If Max Message Length is equal to Min Message Length, the engine will only support barcodes of the length.

Example

To set Min Message Length of Interleaved 2 of 5 as 8 bytes, and Max Message length as 12 bytes, read these programming codes:

1. “Code Programming ON”
2. “Select Min Message Length”
3. Digit Code “8” , see Digit Code Appendix (Pxxx)
4. “Save Programming” , see Digit Code Appendix (Pxxx)
5. “Select Max Message Length”
6. Digit Code “1”
7. Digit Code “2”
8. “Save Programming”
9. “Code Programming OFF”





ITF-6 is a fixed length 6 bytes Interleaved 2 of 5 barcode with check digit.
When enabled, ITF-6 precedes 6-byte Interleaved 2 of 5 barcode.

Code Programming ON



Code Programming OFF



Load ITF-6 Factory Default
【Pro CMD: 99911300】



Enable ITF-6, Do Not Transmit Check Digit
【Pro CMD: 99911301】



Disable ITF-6 User Selection
【Pro CMD: 99911302】



Enable ITF-6, Transmit Check Digit
【Pro CMD: 99911303】



For instance, when ITF-6 is enabled and Interleaved 2 of 5 is disabled, the ITF-6 and 6 bytes Interleaved 2 of 5 with check digit can be read, but other Interleaved 2 of 5 can not.

ITF-6 Code ID



Code ID Setting
【Pro CMD: 99911304】

Example

- Example of setting ITF-6 Code ID to “p” (0x70)
1. Read Enable Code Programming barcode.
 2. Read ITF-6 Code ID Setting barcode.
 3. Read Following Barcodes: “7” , and “0”
 4. Read Save barcode
 5. Read Disable Code Programming barcode.





ITF-14 is a fixed length of 14 bytes Interleaved 2 of 5 barcode with Check digit. By factory default, it is disabled.

When enabled, ITF-14 precedes 14-byte Interleaved 2 of 5 barcode.

Code Programming ON



Code Programming OFF



Load ITF-14 Factory Default
【Pro CMD: 99911400】



Disable ITF-14
【Pro CMD: 99911401】



Enable ITF-14, Do Not Transmit Check Digit
【Pro CMD: 99911402】



Enable ITF-14, Transmit Check Digit
【Pro CMD: 99911403】



For instance, when ITF-14 is enabled and Interleaved 2 of 5 is disabled, the ITF-14 and 14 bytes Interleaved 2 of 5 with check digit can be read, but other Interleaved 2 of 5 can not. If the programming of ITF-14 violates the one of Deutsche 14, ITF-14 precedes Deutsche 14.

ITF-14 Code ID



Code ID Setting
【Pro CMD: 99911404】

Example

Example of setting ITF-14 Code ID to “p” (0x70)

1. Read Enable Code Programming barcode.
2. Read ITF-14 Code ID Setting barcode.
3. Read Following Barcodes: “7” , and “0”
4. Read Save barcode
5. Read Disable Code Programming barcode.



Load Factory Default



Load Deutsche14 Factory Default
【Pro CMD: 99911500】

Code Programming ON



Code Programming OFF



Disable/Enable Deutsche14



Enable Deutsche14, Do Not Transmit Check Digit
【Pro CMD: 99911502】



Disable Deutsche14
【Pro CMD: 99911501】



Enable Deutsche14, Transmit Check Digit
【Pro CMD: 99911503】



When the engine can not read Deutsche14, please read “Enable Deutsche14” and try again. If Deutsche 14 and ITF-14 are enabled at the same time, the engine may mis-decode or has chaos in programming. So it is better to disable ITF-14 if not used.

Deutsche14 Code ID



Code ID Setting
【Pro CMD: 99911504】

E
Example

Example of setting Deutsche14 Code ID to “p” (0x70)

1. Read Enable Code Programming barcode.
2. Read Deutsche14 Code ID Setting barcode.
3. Read Following Barcodes: “7”, and “0”
4. Read Save barcode
5. Read Disable Code Programming barcode.





Load Factory Default



Load Deutshe12 Factory Default
【Pro CMD: 99911600】

Code Programming ON



Code Programming OFF



Disable/Enable Deutshe12



Enable Deutshe12, Do Not Transmit Check Digit
【Pro CMD: 99911602】



Disable Deutshe12
【Pro CMD: 99911601】



Enable Deutshe12, Transmit Check Digit
【Pro CMD: 99911603】



When the engine can not read Deutshe12, please read “Enable Deutshe12” and try again. If Deutsche 12 and ITF-12 are enabled at the same time, the engine may mis-decode or has chaos in programming. So it is better to disable ITF-14 if not used.

Deutshe12 Code ID



Code ID Setting
【Pro CMD: 99911604】

E
Example

Example of setting Deutshe12 Code ID to “p” (0x70)

1. Read Enable Code Programming barcode.
2. Read Deutshe12 Code ID Setting barcode.
3. Read Following Barcodes: “7” , and “0”
4. Read Save barcode
5. Read Disable Code Programming barcode.



Load Factory Default



Load COOP25 Factory Default

【Pro CMD: 99911700】

Code Programming ON



Code Programming OFF



Enable/ Disable COOP25



Enable COOP25
【Pro CMD: 99911702】



Disable COOP25
【Pro CMD: 99911701】



When the engine can not read COOP25, please read “Enable COOP25” and try again.

COOP25 (Japanese Matrix 2 of 5) Code ID



Code ID Setting
【Pro CMD: 99911710】

E
example

Example of setting COOP25 (Japanese Matrix 2 of 5) Code ID to “p” (0x70)

1. Read Enable Code Programming barcode.
2. Read COOP25 (Japanese Matrix 2 of 5) Code ID Setting barcode.
3. Read Following Barcodes: “7” , and “0”
4. Read Save barcode
5. Read Disable Code Programming barcode.





Check Digit

COOP25 may include Check Digit (not compulsory) following its barcode messages. If included, it may be the last digit. It verifies the barcode message.

» “NO Check, Transmit All” means to read without check and transmit all bytes including barcode message and Check Digit.

» “Check, Do Not Transmit Check Digit” means to read and check. If verification is successful, transmits barcode message; if not, engine sends an error beep.

» “Check, Transmit All” means to read and check. If verification is successful, transmits all messages; if not, engine sends an error beep.

Code Programming ON



Code Programming OFF



NO Check, Transmit All
【Pro CMD: 99911703】



Check, Transmit All
【Pro CMD: 99911704】



Check, Do Not Transmit Check Digit
【Pro CMD: 99911705】



When “Check, Do Not Transmit Check Digit” is enabled and barcode message length minus one is less than Min Message Length, it will lead to error beep.

E.g.: Reading a 4-byte (include Check Digit) COOP25 with the Min Message Length being 4 bytes and “Check, Do Not Transmit Check Digit” enabled leads to error beep.



Select Message Length

It is used to program the valid reading length of COOP25. The engine will send an error beep, if the decoded data length does not match the valid length. COOP25 Message Length is defined by “Min. Message Length” and “Max. Message Length” .

Code Programming ON



Code Programming OFF



Min Message Length
【Pro CMD: 99911706】



Max Message Length
【Pro CMD: 99911707】



 ID bar code Message Length should not exceed 255 bytes. If Max Message Length is less than Min Message Length, it means the engine will only support barcodes of the two lengths. If Max Message Length is equal to Min Message Length, the engine will only support barcodes of the length.

Example

To set Min Message Length of COOP25 to 8 bytes and the Max Message Length to 12 bytes. Read these programming code:

1. “Code Programming ON”
2. “Select Min Message Length”
3. Digit Code “8” , see Digit Code (Appendix Pxxx)
4. “Save Programming” , see Digit Code (Appendix Pxxx)
5. “Select Max Message Length”
6. Digit Code “1”
7. Digit Code “2”
8. “Save Programming”
9. “Code Programming OFF”





Load Factory Default



Load Matrix 2 of 5 Factory Default
【Pro CMD: 99912000】

Code Programming ON



Code Programming OFF



Enable/ Disable Matrix 2 of 5



Enable Matrix 2 of 5
【Pro CMD: 99912002】



Disable Matrix 2 of 5
【Pro CMD: 99912001】



When the engine can not read Matrix 2 of 5, please read “Enable Matrix 2 of 5” and try again.

Matrix 2 of 5 Code ID



Code ID Setting
【Pro CMD: 99912010】

E
Example

Example of setting Matrix 2 of 5 Code ID to “p” (0x70)

1. Read Enable Code Programming barcode.
2. Read Matrix 2 of 5 Code ID Setting barcode.
3. Read Following Barcodes: “7” , and “0”
4. Read Save barcode
5. Read Disable Code Programming barcode.





Check Digit

Code Programming ON



Matrix 2 of 5 may include Check Digit (not compulsory) following its barcode messages. If included, it may be the last digit. It verifies the barcode message.

» “NO Check, Transmit All” means to read without check and transmit all bytes including barcode message and Check Digit.

» “Check, Do Not Transmit Check Digit” means to read and check. If verification is successful, transmits barcode message; if not, engine sends an error beep.

» “Check, Transmit All” means to read and check. If verification is successful, transmits all messages; if not, engine sends an error beep.



NO Check, Transmit All
【Pro CMD: 99912003】



Check, Transmit All
【Pro CMD: 99912004】



Check, Do Not Transmit Check Digit
【Pro CMD: 99912005】



When “Check, Do Not Transmit Check Digit” is enabled and barcode message length minus one is less than Min Message Length, it will lead to error beep.
E.g.: Reading a 4-byte (include Check Digit) Matrix 2 of 5 with the Min Message Length being 4 bytes and “Check, Do Not Transmit Check Digit” enabled leads to error beep.



Select Message Length

It is used to program the valid reading length of Matrix 2 of 5. The engine will send an error beep, if the decoded data length does not match the valid length. Matrix 2 of 5 Message Length is defined by “Min. Message Length” and “Max. Message Length” .

Code Programming ON



Code Programming OFF



Min Message Length
【Pro CMD: 99912006】



Max Message Length
【Pro CMD: 99912007】



 ID bar code Message Length should not exceed 255 bytes. If Max Message Length is less than Min Message Length, it means the engine will only support barcodes of the two lengths. If Max Message Length is equal to Min Message Length, the engine will only support barcodes of the length.

Example

To set Min Message Length of Matrix 2 of 5 to 8 bytes and the Max Message Length to 12 bytes. Read these programming code:

1. “Code Programming ON”
2. “Select Min Message Length”
3. Digit Code “8” , see Digit Code (Appendix Pxxx)
4. “Save Programming” , see Digit Code (Appendix Pxxx)
5. “Select Max Message Length”
6. Digit Code “1”
7. Digit Code “2”
8. “Save Programming”
9. “Code Programming OFF”





Load Factory Default



Load Industrial 25 Factory Default

【Pro CMD: 99912100】

Code Programming ON



Code Programming OFF



Enable/ Disable Industrial 25



Enable Industrial 25
【Pro CMD: 99912102】



Disable Industrial 25
【Pro CMD: 99912101】



When the engine can not read Industrial 25, please read “Enable Industrial 25” and try again.

Industrial 25 Code ID



Code ID Setting
【Pro CMD: 99912110】

Example

Example of setting Industrial 25 Code ID to “p” (0x70)

1. Read Enable Code Programming barcode.
2. Read Industrial 25 Code ID Setting barcode.
3. Read Following Barcodes: “7” , and “0”
4. Read Save barcode
5. Read Disable Code Programming barcode.





Check Digit

Industrial 25 may include Check Digit (not compulsory) following its barcode messages. If included, it may be the last digit. It verifies the barcode message.

- » “NO Check, Transmit All” means to read without check and transmit all bytes including barcode message and Check Digit.
- » “Check, Do Not Transmit Check Digit” means to read and check. If verification is successful, transmits barcode message; if not, engine sends an error beep.
- » “Check, Transmit All” means to read and check. If verification is successful, transmits all messages; if not, engine sends an error beep.

Code Programming ON



Code Programming OFF



NO Check, Transmit All
【Pro CMD: 99912103】



Check, Transmit All
【Pro CMD: 99912104】



Check, Do Not Transmit Check Digit
【Pro CMD: 99912105】



When “Check, Do Not Transmit Check Digit” is enabled and barcode message length minus one is less than Min Message Length, it will lead to error beep.
E.g.: Reading a 4-byte (include Check Digit) Industrial 25 with the Min Message Length being 4 bytes and “Check, Do Not Transmit Check Digit” enabled leads to error beep.



Code Programming ON



Code Programming OFF



Select Message Length

It is used to program the valid reading length of Industrial 25. The engine will send an error beep, if the decoded data length does not match the valid length.

Industrial 25 Message Length is defined by “Min. Message Length” and “Max. Message Length” .



Min Message Length
【Pro CMD: 99912106】



Max Message Length
【Pro CMD: 99912107】



 ID bar code Message Length should not exceed 255 bytes. If Max Message Length is less than Min Message Length, it means the engine will only support barcodes of the two lengths. If Max Message Length is equal to Min Message Length, the engine will only support barcodes of the length.

Example

To set Min Message Length of Industrial 25 to 8 bytes and the Max Message Length to 12 bytes. Read these programming code:

1. “Code Programming ON”
2. “Select Min Message Length”
3. Digit Code “8” , see Digit Code (Appendix Pxxx)
4. “Save Programming” , see Digit Code (Appendix Pxxx)
5. “Select Max Message Length”
6. Digit Code “1”
7. Digit Code “2”
8. “Save Programming”
9. “Code Programming OFF”





Load Factory Default



Load Standard 25 Factory Default

【Pro CMD: 99912200】

Code Programming ON



Code Programming OFF



Enable/ Disable Standard 25



Enable Standard 25

【Pro CMD: 99912202】



Disable Standard 25

【Pro CMD: 99912201】



When the engine can not read Standard 25, please read “Enable Standard 25” and try again.

Standard 25 Code ID



Code ID Setting

【Pro CMD: 99912210】

Example

Example of setting Standard 25 Code ID to “p” (0x70)

1. Read Enable Code Programming barcode.
2. Read Standard 25 Code ID Setting barcode.
3. Read Following Barcodes: “7” , and “0”
4. Read Save barcode
5. Read Disable Code Programming barcode.



Check Digit

Standard 25 may include Check Digit (not compulsory) following its barcode messages. If included, it may be the last digit. It verifies the barcode message.

- » “NO Check, Transmit All” means to read without check and transmit all bytes including barcode message and Check Digit.
- » “Check, Do Not Transmit Check Digit” means to read and check. If verification is successful, transmits barcode message; if not, engine sends an error beep.
- » “Check, Transmit All” means to read and check. If verification is successful, transmits all messages; if not, engine sends an error beep.

Code Programming ON



Code Programming OFF



NO Check, Transmit All
【Pro CMD: 99912203】



Check, Transmit All
【Pro CMD: 99912204】



Check, Do Not Transmit Check Digit
【Pro CMD: 99912205】



When “Check, Do Not Transmit Check Digit” is enabled and barcode message length minus one is less than Min Message Length, it will lead to error beep.

E.g.: Reading a 4-byte (include Check Digit) Standard 25 with the Min Message Length being 4 bytes and “Check, Do Not Transmit Check Digit” enabled leads to error beep.



Select Message Length

It is used to program the valid reading length of Standard 25. The engine will send an error beep, if the decoded data length does not match the valid length.

Standard 25 Message Length is defined by “Min. Message Length” and “Max. Message Length” .

Code Programming ON



Code Programming OFF



Min Message Length
【Pro CMD: 99912206】



Max Message Length
【Pro CMD: 99912207】



 ID bar code Message Length should not exceed 255 bytes. If Max Message Length is less than Min Message Length, it means the engine will only support barcodes of the two lengths. If Max Message Length is equal to Min Message Length, the engine will only support barcodes of the length.

Example

To set Min Message Length of Standard 25 to 8 bytes and the Max Message Length to 12 bytes. Read these programming code:

1. “Code Programming ON”
2. “Select Min Message Length”
3. Digit Code “8” , see Digit Code (Appendix Pxxx)
4. “Save Programming” , see Digit Code (Appendix Pxxx)
5. “Select Max Message Length”
6. Digit Code “1”
7. Digit Code “2”
8. “Save Programming”
9. “Code Programming OFF”





Load Factory Default



Load Code 39 Factory Default
【Pro CMD: 99912400】

Code Programming ON



Code Programming OFF



Enable/Disable Code 39



Enable Code 39
【Pro CMD: 99912402】



Disable Code 39
【Pro CMD: 99912401】



When the engine can not read Code 39, please read “Enable Code 39” and try again

Code 39 Code ID



Code ID Setting
【Pro CMD: 99912414】

E
example

- Example of setting Code 39 Code ID to “p” (0x70)
1. Read Enable Code Programming barcode.
 2. Read Code 39 Code ID Setting barcode.
 3. Read Following Barcodes: “7” , and “0”
 4. Read Save barcode
 5. Read Disable Code Programming barcode.



Check Digit

Code 39 may include Check Digit (not compulsory) following its barcode message. It verifies the barcode message.

» "NO Check, Transmit All" means to read without check and transmit all bytes including barcode message and Check Digit.

» "Check, Do Not Transmit Check Digit" means to read and check. If verification is successful, transmits barcode message; if not, engine sends an error beep.

» "Check, Transmit All" means to read and check. If verification is successful, transmits all messages; if not, engine sends an error beep.

Code Programming ON



Code Programming OFF



NO Check, Transmit All
【Pro CMD: 99912403】



Check, Transmit All
【Pro CMD: 99912405】



Check, Do not transmit Check Digit
【Pro CMD: 99912404】



When "Check, Do not Transmit Check digit" is enabled and barcode message length minus one is less than Min Message Length, it will lead to error beep.

E.g.: Reading a 4-byte (include check byte) Code 39 with the Min Message Length being 4 bytes and "Check, Do not transmit Check Digit" enabled leads to error beep.



Transmit Start & Stop Character

Code 39 has one "*" before and another after digits as Start & Stop Character. Transmission of "*" can be selected.

Code Programming ON



Code Programming OFF



Transmit Both "*"
【Pro CMD: 99912407】



Transmit Neither "*"
【Pro CMD: 99912406】

Decode ASCII

Code 39 can include full ASCII characters. For factory default, the engine only decodes part of them. Read "Enable Full ASCII decode" to decode full ASCII characters.



Partial ASCII Decode
【Pro CMD: 99912410】



Full ASCII Decode
【Pro CMD: 99912411】





Select Message Length

Code 39 Message Length is defined by “Min. Message Length” and “Max. Message Length”. It is used to program the valid reading length of Code 39. The engine will send an error beep, if the decoded data length does not match the valid length.

Code Programming ON



Code Programming OFF



Min Message Length
【Pro CMD: 99912412】



Max Message Length
【Pro CMD: 99912413】



1D bar code Message Length should not exceed 255 bytes. If Max Message Length is less than Min Message Length, it means the engine will only support barcodes of the two lengths. If Max Message Length is equal to Min Message Length, the engine will only support barcodes of the length.

Example

To set Min Message Length of Code 39 to 8 bytes, and Max Message Length to 12 bytes, read these programming codes:

1. “Code Programming ON”
2. “Select Min Message Length”
3. Digit Code “8”, see Digit Code (Appendix Pxxx)
4. “Save Programming”, see Digit Code (Appendix Pxxx)
5. “Select Max Message Length”
6. Digit Code “1”
7. Digit Code “2”
8. “Save Programming”
9. “Code Programming OFF”



Load Factory Default



Load Codabar Factory Default
【Pro CMD: 99912500】

Code Programming ON



Code Programming OFF



Enable/Disable Codabar



Enable Codabar
【Pro CMD: 99912502】



Disable Codabar
【Pro CMD: 99912501】



When the engine can not read Codabar, please read “Enable Codabar” and try again.

Codabar Code ID



Code ID Setting
【Pro CMD: 99912516】

E
example

Example of setting Codabar Code ID to “p” (0x70)

1. Read Enable Code Programming barcode.
2. Read Codabar Code ID Setting barcode.
3. Read Following Barcodes: “7” , and “0”
4. Read Save barcode
5. Read Disable Code Programming barcode.



Check Digit

Codabar may include Check Digit (not compulsory) following its barcode message. It verifies the barcode message.

» "NO Check, Transmit All" means to read without check and transmit all bytes including barcode message and Check Digit.

» "Check, Do Not Transmit Check Digit" means to read and check. If verification is successful, transmits barcode message; if not, engine sends an error beep.

» "Check, Transmit All" means to read and check. If verification is successful, transmits all messages; if not, engine sends an error beep.

Code Programming ON



Code Programming OFF



NO Check, Transmit All
【Pro CMD: 99912503】



Check, Do not transmit Check Digit
【Pro CMD: 99912505】



Check, Transmit All
【Pro CMD: 99912504】



When "Check, Do not Transmit Check digit" is enabled and barcode message length minus one is less than Min Message Length, it will lead to error beep.

E.g.: Reading a 4-byte (include check byte) Codabar with the Min Message Length being 4 bytes and "Check, Do not transmit Check Digit" enabled leads to error beep.



Transmit Start & Stop Character

Code Programming ON



Code Programming OFF



Do Not Transmit Both Start & Stop Character
【Pro CMD: 99912506】



Transmit Both Start & Stop Character
【Pro CMD: 99912507】



Use ABCD/ABCD As Start & Stop Character
【Pro CMD: 99912510】



Use ABCD/TN*E As Start & Stop Character
【Pro CMD: 99912511】



Use abcd/abcd As Start & Stop Character
【Pro CMD: 99912512】



Use abcd/tn*e As Start & Stop Character
【Pro CMD: 99912513】





Select Message Length

Codabar Message Length is defined by “Min. Message Length” and “Max. Message Length”. It is used to program the valid reading length of Codabar. The engine will send an error beep, if the decoded data length does not match the valid length.

Code Programming ON



Code Programming OFF



Min Message Length
【Pro CMD: 99912514】



Max Message Length
【Pro CMD: 99912515】



1D bar code Message Length should not exceed 255 bytes. If Max Message Length is less than Min Message Length, it means the engine will only support barcodes of the two lengths. If Max Message Length is equal to Min Message Length, the engine will only support barcodes of the length.

Example

To set Min Message Length of Codabar to 8 bytes, and Max Message Length to 12 bytes, read these programming codes:

1. “Code Programming ON”
2. “Select Min Message Length”
3. Digit Code “8”, see Digit Code (Appendix Pxxx)
4. “Save Programming”, see Digit Code (Appendix Pxxx)
5. “Select Max Message Length”
6. Digit Code “1”
7. Digit Code “2”
8. “Save Programming”
9. “Code Programming OFF”



Load Factory Default



Load Code 93 Factory Default
【Pro CMD: 99912600】

Code Programming ON



Code Programming OFF



Enable /Disable Code 93



Enable Code 93
【Pro CMD: 99912602】



Disable Code 93
【Pro CMD: 99912601】



When the engine can not read Code 93, please read “Enable Code 93” and try again.

Code 93 Code ID



Code ID Setting
【Pro CMD: 99912610】

E xample

Example of setting Code 93 Code ID to “p” (0x70)

1. Read Enable Code Programming barcode.
2. Read Code 93 Code ID Setting barcode.
3. Read Following Barcodes: “7” , and “0”
4. Read Save barcode
5. Read Disable Code Programming barcode.





Check Digit

Code 93 may include Check Digits (not compulsory) following its barcode message. If included, they are the last two digits. They verify the barcode message.

» "NO Check, Transmit All" means to read without check and transmit all bytes including barcode message and Check Digit.

» "Check, Do Not Transmit Check Digit" means to read and check. If verification is successful, transmits barcode message; if not, engine sends an error beep.

» "Check, Transmit All" means to read and check. If verification is successful, transmits all messages; if not, engine sends an error beep.

Code Programming ON



Code Programming OFF



NO Check, Transmit All
【Pro CMD: 99912603】



Check, Do not transmit Check Digit
【Pro CMD: 99912604】



Check, Transmit All
【Pro CMD: 99912605】



When "Check, Do not Transmit Check digit" is enabled and barcode message length minus one is less than Min Message Length, it will lead to error beep.

E.g.: Reading a 4-byte (include check byte) Code 93 with the Min Message Length being 4 bytes and "Check, Do not transmit Check Digit" enabled leads to error beep.



Select Message Length

It is used to program the valid reading length of Code 93. The engine will send an error beep, if the decoded data length does not match the valid length.

Code 93 Message Length is defined by “Min. Message Length” and “Max. Message Length .”

Code Programming ON



Code Programming OFF



Min Message Length

【Pro CMD: 99912606】



Max Message Length

【Pro CMD: 99912607】



1D bar code Message Length should not exceed 255 bytes. If Max Message Length is less than Min Message Length, it means the engine will only support barcodes of the two lengths. If Max Message Length is equal to Min Message Length, the engine will only support barcodes of the length.

Example

To set Min Message Length of Code 93 to 8 bytes and Max Message Length to 12 bytes, read these programming codes:

1. “Code Programming ON”
2. “Select Min Message Length”
3. Digit Code “8” , see Digit Code (Appendix Pxxx)
4. “Save Programming” , see Digit Code (Appendix Pxxx)
5. “Select Max Message Length”
6. Digit Code “1”
7. Digit Code “2”
8. “Save Programming”
9. “Code Programming OFF”



Load Factory Default



Load Code 11 Factory Default

【Pro CMD: 99912700】

Code Programming ON



Code Programming OFF



Enable/ Disable Code 11



Enable Code 11

【Pro CMD: 99912702】



Disable Code 11

【Pro CMD: 99912701】



When the engine can not read Code 11, please read “Enable Code 11” and try again.

Code 11 Code ID



Code ID Setting

【Pro CMD: 99912715】

Example

Example of setting Code 11 Code ID to “p” (0x70)

1. Read Enable Code Programming barcode.
2. Read Code 11 Code ID Setting barcode.
3. Read Following Barcodes: “7” , and “0”
4. Read Save barcode
5. Read Disable Code Programming barcode.





Check Digit

Code 11 may include Check Digit (not compulsory) following its barcode messages. If included, it may be the last one or two digits. It verifies the barcode message.

» “NO Check, Transmit All” means to read without check and transmit all bytes including barcode message and Check Digit.

Code Programming ON



Code Programming OFF



No Check

【Pro CMD: 99912703】



Single Check Digit, MOD11

【Pro CMD: 99912704】



Double Check Digits, MOD11/MOD11

【Pro CMD: 99912705】



Double Check Digits, MOD11/MOD9

【Pro CMD: 99912706】



Single Check Digit MOD11 (Len <= 10)

Double Check Digits MOD11/
MOD11 (Len > 10)

【Pro CMD: 99912707】



Single Check Digit MOD11 (Len <= 10)

Double Check Digits MOD11/
MOD9 (Len > 10)

【Pro CMD: 99912710】



Do not transmit Check Digit

【Pro CMD: 99912711】



Transmit Check Digit

【Pro CMD: 99912712】



When “Check, Do Not Transmit Check Digit” is enabled and barcode message length minus one is less than Min Message Length, it will lead to error beep.
E.g.: Reading a 4-byte (include Check Digit) Code 11 with the Min Message Length being 4 bytes and “Check, Do Not Transmit Check Digit” enabled leads to error beep.



Select Message Length

It is used to program the valid reading length of Code 11. The engine will send an error beep, if the decoded data length does not match the valid length.

Code 11 Message Length is defined by “Min. Message Length” and “Max. Message Length” .

Code Programming ON



Code Programming OFF



Min Message Length
【Pro CMD: 99912713】



Max Message Length
【Pro CMD: 99912714】



ID bar code Message Length should not exceed 255 bytes. If Max Message Length is less than Min Message Length, it means the engine will only support barcodes of the two lengths. If Max Message Length is equal to Min Message Length, the engine will only support barcodes of the length.

Example

To set Min Message Length of Code 11 to 8 bytes and the Max Message Length to 12 bytes. Read these programming code:

1. “Code Programming ON”
2. “Select Min Message Length”
3. Digit Code “8” , see Digit Code (Appendix Pxxx)
4. “Save Programming” , see Digit Code (Appendix Pxxx)
5. “Select Max Message Length”
6. Digit Code “1”
7. Digit Code “2”
8. “Save Programming”
9. “Code Programming OFF”





Load Factory Default



Load Plessey Factory Default

【Pro CMD: 99913000】

Code Programming ON



Code Programming OFF



Enable/ Disable Plessey



Enable Plessey

【Pro CMD: 99913002】



Disable Plessey

【Pro CMD: 99913001】



When the engine can not read Plessey, please read “Enable Plessey” and try again.

Plessey Code ID



Code ID Setting

【Pro CMD: 99913010】

E
example

Example of setting Plessey Code ID to “p” (0x70)

1. Read Enable Code Programming barcode.
2. Read Plessey Code ID Setting barcode.
3. Read Following Barcodes: “7” , and “0”
4. Read Save barcode
5. Read Disable Code Programming barcode.





Check Digit

Plessey may include Check Digits (not compulsory) following its barcode messages. If included, they are the last two digit. They verify the barcode message.

Code Programming ON



Code Programming OFF



» “NO Check, Transmit All” means to read without check and transmit all bytes including barcode message and Check Digit.

» “Check, Do Not Transmit Check Digit” means to read and check. If verification is successful, transmits barcode message; if not, engine sends an error beep.

» “Check, Transmit All” means to read and check. If verification is successful, transmits all messages; if not, engine sends an error beep.



NO Check, Transmit All
【Pro CMD: 99913003】



Check, Do not transmit Check Digit
【Pro CMD: 99913005】



Check, Transmit All
【Pro CMD: 99913004】



When “Check, Do Not Transmit Check Digit” is enabled and barcode message length minus one is less than Min Message Length, it will lead to error beep.

E.g.: Reading a 4-byte (include Check Digit) Plessey with the Min Message Length being 4 bytes and “Check, Do Not Transmit Check Digit” enabled leads to error beep.



Select Message Length

It is used to program the valid reading length of Plessey. The engine will send an error beep, if the decoded data length does not match the valid length.

Plessey Message Length is defined by “Min. Message Length” and “Max. Message Length” .

Code Programming ON



Code Programming OFF



Min Message Length
【Pro CMD: 99913006】



Max Message Length
【Pro CMD: 99913007】



 ID bar code Message Length should not exceed 255 bytes. If Max Message Length is less than Min Message Length, it means the engine will only support barcodes of the two lengths. If Max Message Length is equal to Min Message Length, the engine will only support barcodes of the length.

Example

To set Min Message Length of Plessey to 8 bytes and the Max Message Length to 12 bytes. Read these programming code:

1. “Code Programming ON”
2. “Select Min Message Length”
3. Digit Code “8” , see Digit Code (Appendix Pxxx)
4. “Save Programming” , see Digit Code (Appendix Pxxx)
5. “Select Max Message Length”
6. Digit Code “1”
7. Digit Code “2”
8. “Save Programming”
9. “Code Programming OFF”



Load Factory Default



Load MSI-Plessey Factory Default

【Pro CMD: 99913100】

Code Programming ON



Code Programming OFF



Enable/ Disable MSI-Plessey



Enable MSI-Plessey
【Pro CMD: 99913102】



Disable MSI-Plessey
【Pro CMD: 99913101】



When the engine can not read MSI-Plessey, please read “Enable MSI-Plessey” and try again.

MSI-Plessey Code ID



Code ID Setting
【Pro CMD: 99913113】

E
example

Example of setting MSI-Plessey Code ID to “p” (0x70)

1. Read Enable Code Programming barcode.
2. Read MSI-Plessey Code ID Setting barcode.
3. Read Following Barcodes: “7” , and “0”
4. Read Save barcode
5. Read Disable Code Programming barcode.





Check Digit

MSI-Plessey may include Check Digit (not compulsory) following its barcode messages. If included, it may be the last one or two digits. It verifies the barcode message.

» “NO Check, Transmit All” means to read without check and transmit all bytes including barcode message and Check Digit.

Code Programming ON



Code Programming OFF



No Check

【Pro CMD: 99913103】



Single Check Digit, MOD10

【Pro CMD: 99913104】



Double Check Digits, MOD10/MOD10

【Pro CMD: 99913105】



Double Check Digits, MOD10/MOD11

【Pro CMD: 99913106】



Do not transmit Check Digit

【Pro CMD: 99913107】



Transmit Check Digit

【Pro CMD: 99913110】



When “Check, Do Not Transmit Check Digit” is enabled and barcode message length minus one is less than Min Message Length, it will lead to error beep.

E.g.: Reading a 4-byte (include Check Digit) MSI-Plessey with the Min Message Length being 4 bytes and “Check, Do Not Transmit Check Digit” enabled leads to error beep.



Select Message Length

MSI-Plessey Message Length is defined by “Min. Message Length” and “Max. Message Length”. It is used to program the valid reading length of MSI-Plessey. The engine will send an error beep, if the decoded data length does not match the valid length.

Code Programming ON



Code Programming OFF



Min Message Length
【Pro CMD: 99913111】



Max Message Length
【Pro CMD: 99913112】



 ID bar code Message Length should not exceed 255 bytes. If Max Message Length is less than Min Message Length, it means the engine will only support barcodes of the two lengths. If Max Message Length is equal to Min Message Length, the engine will only support barcodes of the length.

Example

To set Min Message Length of MSI-Plessey to 8 bytes and the Max Message Length to 12 bytes. Read these programming code:

1. “Code Programming ON”
2. “Select Min Message Length”
3. Digit Code “8”, see Digit Code (Appendix Pxxx)
4. “Save Programming”, see Digit Code (Appendix Pxxx)
5. “Select Max Message Length”
6. Digit Code “1”
7. Digit Code “2”
8. “Save Programming”
9. “Code Programming OFF”



Load Factory Default



Load GS1 Databar Factory Default

【Pro CMD: 99913200】

Code Programming ON



Code Programming OFF



Enable/ Disable GS1 Databar



Enable GS1 Databar

【Pro CMD: 99913202】



Disable GS1 Databar

【Pro CMD: 99913201】



When the engine can not read GS1 Databar, please read “Enable GS1 Databar” and try again.

GS1 Databar Code ID



Code ID Setting

【Pro CMD: 99913203】

E xample

Example of setting GS1 Databar Code ID to “p” (0x70)

1. Read Enable Code Programming barcode.
2. Read GS1 Databar Code ID Setting barcode.
3. Read Following Barcodes: “7” , and “0”
4. Read Save barcode
5. Read Disable Code Programming barcode.





Appendix

Factory Default List

Parameters	Factory Default	Remark
General Programming		
Code Programming	On	
Send Pro Code Value	Off	
Working Mode	Hand-held Mode	
Reading a Barcode Time Length	3s	Range: 0-15s, 0 is infinite time.
Timeout between Decodes (Same barcode)	1.6s	Applicable to Sensor Mode and Continuous Mode 0.0-12.0s; 12.7s: infinite time
Interval Length	1s	Range: 0-7.5s
Sensitivity	High Sensitivity	Applicable to Sensor Mode
Security Level	Level 1	
Good Read Beep	Medium Frequency & Loud Volume, 150ms sound length	
Reading Same Barcode	Off	Applicable to Auto Mode
Restart Timer After a valid Reading	On	Applicable to Auto Mode
Auto Sleep	Off	Applicable to Hand-held Mode
Auto Sleep Option	Sleep Mode	Applicable to Hand-held Mode
Idle Timeout	6.0s	Applicable to Hand-held Mode Range: 0.0-6.0s
Communication Programming		
Baud Rate	9600	
Serial Port Check	No Check	
Stop Digit	1 Digit	Fixed
Flow Controlling	No Flow Controlling	Fixed
Data Bit	8 Bit	
Data Format Programming		
Prefix Sequences	Code ID+User Prefix+AIM ID	CodeID+Prefix+(AIM ID+Data) +Suffix+Terminal
AIM ID	Off]Cm Mark
Code ID	Off	One or two digit, capital or small letters
User Prefix	Off	No more than 11 digits
User Suffix	Off	No more than 11 digits
Terminal	Off	No more than 7 digits



Parameters	Factory Default	Remark
Symbol		
Code 128		
Enable	On	
Max Message Length	255	
Min Message Length	1	
UCC/EAN-128		
Enable	On	
Max Message Length	255	
Min Message Length	1	
AIM 128		
Enable	Off	
Min Message Length	1	
EAN-8		
Enable	On	
Send Check Digit	On	
Enable 2 Digits Addenda Code	Off	
Enable 5 Digits Addenda Code	Off	
Only Read With 2 digits Addenda Code	Off	
Only Read With 5 digits Addenda Code	Off	
Expand to EAN-13	Off	
Expand and Change Type to EAN-13	Off	
EAN-13		
Enable	On	
Send Check Digit	On	
Enable 2 Digits Addenda Code	Off	
Enable 5 Digits Addenda Code	Off	
Only Read With 2 digits Addenda Code	Off	
Only Read With 5 digits Addenda Code	Off	





ISSN		
Enable	Off	
ISBN		
Enable	Off	
Use 10 Digits	Off	
UPC-E		
Enable	On	
Send Check Digit	On	
Enable 2 Digits Addenda Code	Off	
Enable 5 Digits Addenda Code	Off	
Only Read With 2 digits Addenda Code	Off	
Only Read With 5 digits Addenda Code	Off	
Expand to UPC-A	Off	
Expand and Change Type to UPC-A	Off	
Send System Character	Off	
Send Country Code	Off	
UPC-A		
Enable	On	
Send Check Digit	On	
Enable 2 Digits Addenda Code	Off	
Enable 5 Digits Addenda Code	Off	
Only Read With 2 digits Addenda Code	Off	
Only Read With 5 digits Addenda Code	Off	
Send System Character	On	
Send Country Code	Off	
Interleaved 2 of 5		
Enable	On	
Check	On	
Send Check Digit	Off	
Max Message Length	255	
Min Message Length	6	No less than 2
ITF-6		
Enable	Off	
Send Check Digit	On	
ITF-14		
Enable	Off	
Send Check Digit	On	





Deutsche 14		
Enable	Off	
Send Check Digit	On	
Deutsche 12		
Enable	Off	
Send Check Digit	On	
COOP 25(Japanese Matrix 2 of 5)		
Enable	Off	
Check	Off	
Send Check Digit	Off	
Max Message Length	255	
Min Message Length	6	No less than 3
Matrix 2 of 5(European Matrix 2 of 5)		
Enable	On	
Check	Off	
Send Check Digit	Off	
Max Message Length	255	
Min Message Length	6	No less than 3
Industrial 25		
Enable	On	
Check	Off	
Send Check Digit	Off	
Max Message Length	255	
Min Message Length	6	No less than 4
Standard 25		
Enable	On	IATA 25
Check	Off	
Send Check Digit	Off	
Max Message Length	255	
Min Message Length	6	No less than 4
Code 39		
Enable	On	
Check	Off	
Send Check Digit	Off	
Send Start & Stop Character	On	





Support Full ASCII	On	
Max Message Length	255	
Min Message Length	4	No less than 1
Codabar		
Enable	On	
Check	Off	
Send Check Digit	Off	
Send Start & Stop Character	On	
ABCD/ABCD as Start & Stop Character	On	Choose 1 In 4
ABCD/TN*E as Start & Stop Character	Off	
abcd/abcd as Start & Stop Character	Off	
abcd/tn*e as Start & Stop Character	Off	
Max Message Length	255	
Min Message Length	4	No less than 2
Code 93		
Enable	On	
Check	On	
Send Check Digit	Off	
Max Message Length	255	
Min Message Length	2	No less than 1
Code 11		
Enable	Off	
Send Check Digit	Off	
Check	On	
1 Digit, MOD11 Check	On	
2 Digits, MOD11/MOD11 Check	Off	
2 Digits, MOD11/MOD9 Check	Off	
Auto 2 Digits, MOD11/MOD11	Off	
Auto 2 Digits, MOD11/MOD9	Off	
Max Message Length	255	
Min Message Length	4	No less than 3
Plssey		
Enable	Off	
Check	On	
Send Check Digit	Off	





Max Message Length	255	
Min Message Length	4	No less than 4
<i>MSI-Plessey</i>		
Enable	Off	
Send Check Digit	Off	
Check	On	
1 Digit, MOD10 Check	Off	
2 Digits, MOD10/MOD10 Check	Off	
2 Digits, MOD10/MOD11 Check	Off	
Max Message Length	255	
Min Message Length	4	No less than 4
<i>GSI Databar</i>		
Enable	On	
Max Message Length	255	
Min Message Length	1	





Symbol	AIM ID	Possible AIM ID Modifiers(m)
Code 128]C0	
UCC/EAN-128]C1	
AIM 128]C2	
ISBT 128]C4	
EAN-8]E4	
EAN-13]E0	
EAN-13 with Addon]E3	
ISSN]X0	
ISBN]X0	
UPC-E]E0	
UPC-E with Addon]E3	
UPC-A]E0	
UPC-A with Addon]E3	
Interleaved 2 of 5]Im	0,1,3
ITF-6]Im	1,3
ITF-14]Im	1,3
Deutsche 14]X0	
Deutsche 12]X0	
COOP 25 (Japanese Matrix 2 of 5)]X0	
Matrix 2 of 5(European Matrix 2 of 5)]X0	
Industrial 25]S0	
Standard 25]R0	
Code 39]Am	0,1,3,4,5,7
Codabar]Fm	0,2,4
Code 93]G0	
Code 11]Hm	0,1,3
Plessey]P0	
MSI-Plessey]Mm	0,1
GS1 Databar]e0	

Reference:

- » ISO/IEC 15424:2008
- » Information technology – Automatic identification and data capture techniques – Data Carrier Identifiers (including Symbology Identifiers)





Symbol	Code ID
Code 128	j
UCC/EAN-128	u
AIM 128	f
ISBT 128	t
EAN-8	g
EAN-13	d
ISSN	n
ISBN	B
UPC-E	h
UPC-A	c
Interleaved 2 of 5	e
ITF-6	r
ITF-14	q
Deutsche 14	w
Deutsche 12	l
COOP 25 (Japanese Matrix 2 of 5)	o
Matrix 2 of 5(European Matrix 2 of 5)	v
Industrial 25	i
Standard 25	s
Code 39	b
Codabar	a
Code 93	y
Code 11	z
Plessey	p
MSI-Plessey	m
GS1 Databar	R





It is must to read save after reading digit code.

Code Programming ON



Code Programming OFF



0

【Pro CMD: 99900000】



4

【Pro CMD: 99900004】



1

【Pro CMD: 99900001】



5

【Pro CMD: 99900005】



2

【Pro CMD: 99900002】



6

【Pro CMD: 99900006】



3

【Pro CMD: 99900003】



7

【Pro CMD: 99900007】





Code Programming ON



Code Programming OFF



8

【Pro CMD: 99900010】



C

【Pro CMD: 99900014】



9

【Pro CMD: 99900011】



D

【Pro CMD: 99900015】



A

【Pro CMD: 99900012】



E

【Pro CMD: 99900016】



B

【Pro CMD: 99900013】



F

【Pro CMD: 99900017】





In order to save the received data “Save” has to be read after data transition completed. If error occurs when reading data, the wrong data can be deleted and the setting up can be done again..

Eg, after a program code is received then ‘1 2 3’ in order is received, if then read “Abort One Data of Current Setting” the “3” will be deleted; if read “Abort One String of Current Setting” the ‘123’ will be deleted; if read “Abort Current Setting” both the program code and ‘123’ will be deleted, the device will be on status of “initiating program code” .

Code Programming ON



Code Programming OFF



Save

【Pro CMD: 99900020】



Abort One Data of Current Setting

【Pro CMD: 99900021】



Abort Current Setting

【Pro CMD: 99900023】



Abort All String of Current Setting

【Pro CMD: 99900022】





Hex	Dec	Char
00	0	NUL (Null char.)
01	1	SOH (Start of Header)
02	2	STX (Start of Text)
03	3	ETX (End of Text)
04	4	EOT (End of Transmission)
05	5	ENQ (Enquiry)
06	6	ACK (Acknowledgment)
07	7	BEL (Bell)
08	8	BS (Backspace)
09	9	HT (Horizontal Tab)
0a	10	LF (Line Feed)
0b	11	VT (Vertical Tab)
0c	12	FF (Form Feed)
0d	13	CR (Carriage Return)
0e	14	SO (Shift Out)
0f	15	SI (Shift In)
10	16	DLE (Data Link Escape)
11	17	DC1 (XON) (Device Control 1)
12	18	DC2 (Device Control 2)
13	19	DC3 (XOFF) (Device Control 3)
14	20	DC4 (Device Control 4)
15	21	NAK (Negative Acknowledgement)
16	22	SYN (Synchronous Idle)
17	23	ETB (End of Trans. Block)
18	24	CAN (Cancel)
19	25	EM (End of Medium)
1a	26	SUB (Substitute)
1b	27	ESC (Escape)
1c	28	FS (File Separator)
1d	29	GS (Group Separator)
1e	30	RS (Request to Send)
1f	31	US (Unit Separator)
20	32	SP (Space)
21	33	! (Exclamation Mark)
22	34	" (Double Quote)
23	35	# (Number Sign)
24	36	\$ (Dollar Sign)
25	37	% (Percent)
26	38	& (Ampersand)
27	39	` (Single Quote)
28	40	((Right / Closing Parenthesis)
29	41) (Right / Closing Parenthesis)
2a	42	* (Asterisk)
2b	43	+ (Plus)
2c	44	, (Comma)





Hex	Dec	Char
2d	45	- (Minus / Dash)
2e	46	. (Dot)
2f	47	/ (Forward Slash)
30	48	0
31	49	1
32	50	2
33	51	3
34	52	4
35	53	5
36	54	6
37	55	7
38	56	8
39	57	9
3a	58	: (Colon)
3b	59	; (Semi-colon)
3c	60	< (Less Than)
3d	61	= (Equal Sign)
3e	62	> (Greater Than)
3f	63	? (Question Mark)
40	64	@ (AT Symbol)
41	65	A
42	66	B
43	67	C
44	68	D
45	69	E
46	70	F
47	71	G
48	72	H
49	73	I
4a	74	J
4b	75	K
4c	76	L
4d	77	M
4e	78	N
4f	79	O
50	80	P
51	81	Q
52	82	R
53	83	S
54	84	T
55	85	U
56	86	V
57	87	W
58	88	X





Hex	Dec	Char
59	89	Y
5a	90	Z
5b	91	[(Left / Opening Bracket)
5c	92	\ (Back Slash)
5d	93] (Right / Closing Bracket)
5e	94	^ (Caret / Circumflex)
5f	95	_ (Underscore)
60	96	' (Grave Accent)
61	97	a
62	98	b
63	99	c
64	100	d
65	101	e
66	102	f
67	103	g
68	104	h
69	105	i
6a	106	j
6b	107	k
6c	108	l
6d	109	m
6e	110	n
6f	111	o
70	112	p
71	113	q
72	114	r
73	115	s
74	116	t
75	117	u
76	118	v
77	119	w
78	120	x
79	121	y
7a	122	z
7b	123	{ (Left/ Opening Brace)
7c	124	(Vertical Bar)
7d	125	} (Right/Closing Brace)
7e	126	~ (Tilde)
7f	127	DEL (Delete)





Newland

SCANNING MADE SIMPLE

Newland EMEA HQ

+31 (0) 345 87 00 33
info@newland-id.com
newland-id.com

D-A-C-H

+49 (0) 6182 82916-16
info@newland-id.de

Benelux

+31 (0) 345 87 00 33
benelux@newland-id.com

Italy

+39 (0) 342 0562227
italy@newland-id.com

United Kingdom

+44 (0) 1442 212020
sales@newland-id.co.uk

South Africa

Gauteng: +27 (0) 11 553 8010
Cape Town: +27 (0) 21 9140819
info@newland-id.co.za

Turkey

+90 (0) 544 538 40 49
turkey@newland-id.com

France

+39 (0) 345 8804096
france@newland-id.com

Ibérica

+34 (0) 93 303 74 66
info@newland-id.es

Nordic & Baltic

+46 (0) 70 88 47 767
nordic@newland-id.com

Russia

+31 (0) 345 87 00 33
russia@newland-id.com

Middle East

+39 (0) 345 8804096
middleeast@newland-id.com

Iran

+90 (0) 544 538 40 49
iran@newland-id.com