

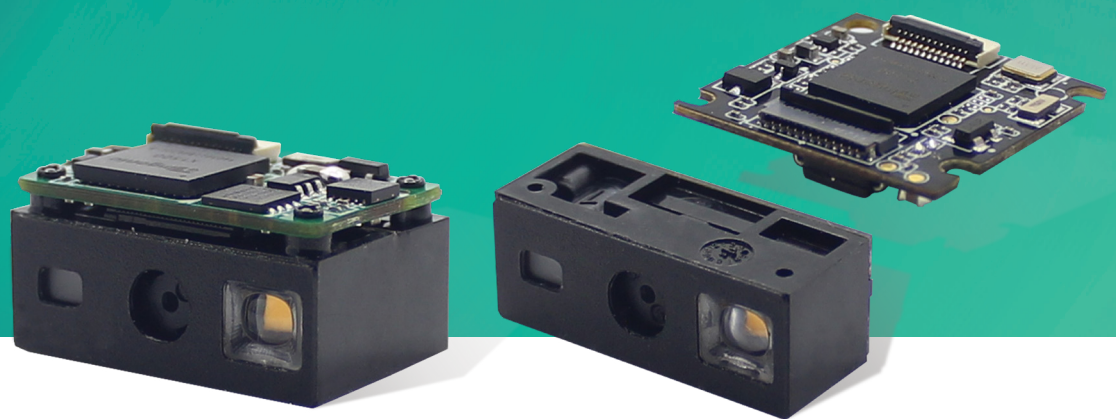

Newland

SCANNING MADE SIMPLE



EM50S-10 / EM50S-20

OEM scan engine

integration guide

Disclaimer

© 2019 Fujian Newland Auto-ID Tech. Co., Ltd. All rights reserved.

Please read through the manual carefully before using the product and operate it according to the manual. It is advised that you should keep this manual for future reference.

Do not disassemble the device or remove the seal label from the device, doing so will void the product warranty provided by Fujian Newland Auto-ID Tech. Co., Ltd.

All pictures in this manual are for reference only and actual product may differ. Regarding to the product modification and update, Fujian Newland Auto-ID Tech. Co., Ltd. reserves the right to make changes to any software or hardware to improve reliability, function, or design at any time without notice. The information contained herein is subject to change without prior notice.

The products depicted in this manual may include software copyrighted by Fujian Newland Auto-ID Tech. Co., Ltd or third party. The user, corporation or individual, shall not duplicate, in whole or in part, distribute, modify, decompile, disassemble, decode, reverse engineer, rent, transfer or sublicense such software without prior written consent from the copyright holders.

This manual is copyrighted. No part of this publication may be reproduced, distributed or used in any form without written permission from Newland.

Fujian Newland Auto-ID Tech. Co., Ltd. reserves the right to make final interpretation of the statement above.

Fujian Newland Auto-ID Tech. Co., Ltd.

3F, Building A, No.1, Rujiang West Rd., Mawei, Fuzhou, Fujian, China 350015

<http://www.newlandaidc.com>

Revision History

Version	Description	Date
V1.0.0	Initial release.	April 16, 2019

Table of Contents

Revision History	- 3 -
About This Guide.....	1
Introduction.....	1
Chapter Description.....	1
Explanation of Symbols.....	1
Related Documents.....	2
Chapter 1 Getting Started	3
Introduction.....	3
Illumination	4
Aimer.....	4
Chapter 2 Installation	5
Introduction.....	5
General Requirements	5
ESD	5
Avoid Hot-plugging.....	5
Dust and Dirt.....	5
Ambient Environment.....	5
Thermal Considerations.....	6
External Optical Elements.....	6
Installation Orientation	6
Mounting.....	7
Mechanical Mounting Dimensions for EM50S-10 (Unit: mm).....	7
Mechanical Mounting Dimensions for EM50S-20 (Unit: mm).....	8
Housing Design	11
Optics	11
Window Placement	11
Window Material and Color.....	12
Coatings and Scratch Resistance	13
Window Size	13
EM50S-10.....	14
EM50S-20.....	15
Roll, Skew and Pitch.....	16
Ambient Light.....	16

Eye Safety.....	16
Chapter 3 Electrical Specifications.....	17
Power Supply	17
Ripple Noise.....	17
DC Characteristics	17
Operating Voltage / Current	17
I/O Voltage	18
Timing Sequence.....	18
Power Up and Power Down Timing Sequence	18
Chapter 4 Interfaces.....	19
Interface Pinouts	19
12-pin FPC Connector	20
Connector/Cable Specifications (Unit: mm).....	21
12-pin FPC Connector	22
12-pin FFC Cable.....	23
External Circuit Design.....	24
Good Read LED Circuit	24
Beeper Circuit	24
Trigger Circuit.....	25
External Illumination LED Circuit.....	25
Reset Circuit	26
Chapter 5 Auxiliary Tools.....	27
EVK.....	27
EasySet.....	27

About This Guide

Introduction

The NLS-EM50S-10/NLS-EM50S-20 OEM scan engines (hereinafter referred to as “the EM50S ” or “the engine”) are armed with CMOS image capturer and the Newland patented **UIMG**[®], a computerized image recognition system-on-chip, featuring fast scanning and accurate decoding on barcodes on virtually any medium-paper, magnetic card, mobile phones and LCD displays. The EM50S can be easily integrated into OEM equipment or systems, such as handheld, portable, or stationary barcode scanners. The EM50S offers fully open image acquisition interface, raw data interface and I/O interface, which enable users to easily develop their own applications with Newland’s SDK.

※ Note: This guide provides general instructions for the installation of the engine into a customer's device. Fujian Newland Auto-ID Tech. Co., Ltd. recommends an opto-mechanical engineer should conduct an opto-mechanical analysis before integration.

Chapter Description

Chapter 1, Getting Started	Gives a general description of the EM50S.
Chapter 2, Installation	Describes how to install the engine, including installation information, housing design, optical, grounding, ESD, and environmental considerations.
Chapter 3, Electrical Specifications	Includes the electrical characteristics for the engine and timing sequences.
Chapter 4, Interfaces	Includes interface pinout and connector/cable specifications.
Chapter 5, Auxiliary Tools	Introduces useful tools you can use to test and evaluate the EM50S as well as conduct secondary development.

Explanation of Symbols

- This symbol indicates lists of required steps.
- ※ This symbol indicates something important to the readers. Failure to read the notice will not lead to harm to the reader, device or data.
- ⚠ This symbol indicates caution that, if ignored, may cause data or device damage or even personal injury.

Related Documents

- 12-pin FPC connector specification, HIROSE Corporation, Model: FH34SRJ-12S-0.5SH(50), <https://www.hirose.com/cn/>

Chapter 1 Getting Started

Introduction

The EM50S is an area image engine for barcode reading. It includes a laser aiming system, an LED illumination system and a 12-pin FPC connector.

LED Compliance Statement

The EM50S complies with IEC 62471:2006 for LED safety.

Laser Compliance Statement

The EM50S is certified to be in compliance with IEC 60825-1:2014 as a class 1 laser product.

The EM50S contains:

- a CPU decoder board
- a CMOS image sensor and its lens
- an LED illumination system
- a laser aiming system
- a 12-pin FPC connector

Figure 1-1 System Block Diagram

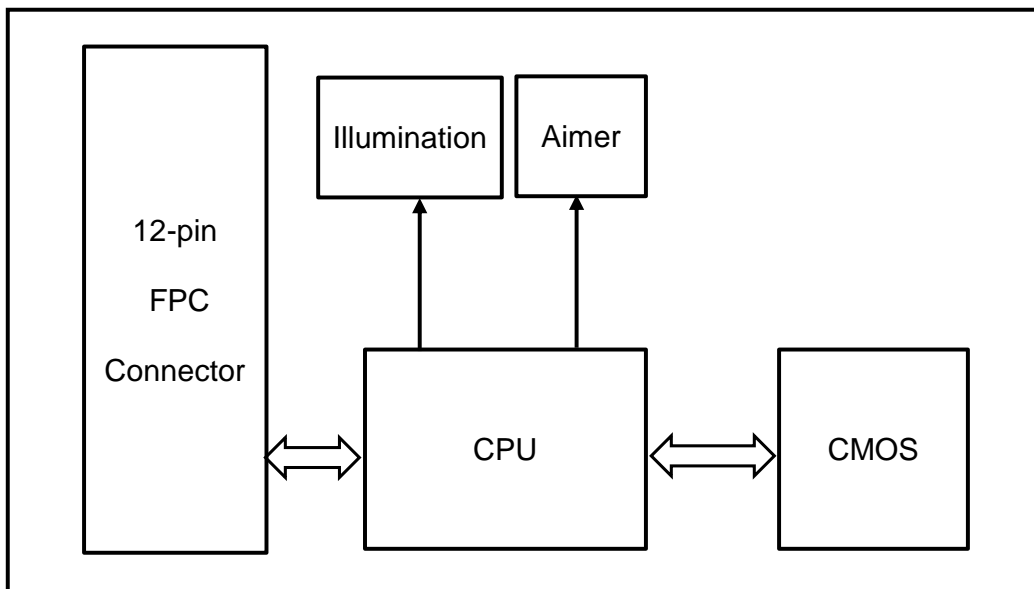

The 12-pin FPC connector on the engine can be connected to a host device with an FFC cable. For information about this cable, please see the “12-pin FFC Cable” section in Chapter 4.

Illumination

The EM50S has a white LED for supplementary lighting, making it possible to scan barcodes even in complete darkness. The illumination can be turned On or Off. Besides, external illumination LED for further improving lighting can be turned On by programming PIN 8 of the 12-pin FPC connector on the engine when needed.

Aimer

The EM50S contains a laser aimer that produces a crosshair aiming pattern to help the user to easily position the target barcode within the engine’s field of view to increase scan efficiency. The aiming pattern can be turned On or Off. It is advisable to turn it on when scanning barcodes.

Chapter 2 Installation

Introduction

This chapter explains how to install the EM50S, including general requirements, housing design, and physical and optical information.

- △ Caution: Do not touch the imaging lens when installing the engine. Be careful not to leave fingerprints on the lens.
- △ Caution: Do not touch the illumination LED or diffractive optical element during handling. Improper handling may affect engine performance.

General Requirements

ESD

ESD protection has been taken into account when designing the EM50S. However, due to limited board space, additional ESD protection, such as TVS protection, is not provided on the engine's I/O interface. It is advised to take corresponding protection measures when integrating the engine.

The engine is shipped in ESD safe packaging. Always exercise care when handling the engine outside its package. Be sure grounding wrist straps and properly grounded work areas are used.

Avoid Hot-plugging

The EM50S does not support hot-plugging. Be sure the power is cut off before connecting a cable to or disconnecting a cable from the engine. Hot-plugging could damage the engine.

Dust and Dirt

The EM50S must be sufficiently enclosed to prevent dust particles from gathering on the lens and circuit board. Dust and other external contaminants will eventually degrade the engine's performance.

Ambient Environment

The following environmental requirements should be met to ensure good performance of the EM50S.

Table 2-1: EM50S-10

Operating Temperature	-20°C to 60°C
Storage Temperature	-40°C to 70°C
Humidity	5% ~95% (non-condensing)

Table 2-2: EM50S-20

Operating Temperature	-20°C to 60°C
Storage Temperature	-40°C to 70°C
Humidity	5% ~95% (non-condensing)

Thermal Considerations

Electronic components in the EM50S will generate heat during the course of their operation. Operating the EM50S in continuous mode for an extended period may cause temperatures to rise on CPU, CIS, LEDs, DC/DC, etc and could result in a 40°C (EM50S-10) /35°C (EM50S-20) increase inside the engine. Overheating can degrade image quality and affect scanning performance. Given that, the following precautions should be taken into consideration when integrating the EM50S.

- ✧ Avoid continuous use of the engine for prolonged periods.
- ✧ Reserve sufficient space for good air circulation in the design.
- ✧ Avoid wrapping the engine with thermal insulation materials such as rubber.
- ✧ Use thermally conductive but electrically insulating material to conduct heat to the housing of the engine.

External Optical Elements

Do not subject external optical components on the engine to any external force. Do not hold the engine by an external optical component, which may cause the mechanical joints that secure the components to crack or break due to excessive stress.

Installation Orientation

The **Figure 2-1** illustrates a front view of the EM50S after correct installation.

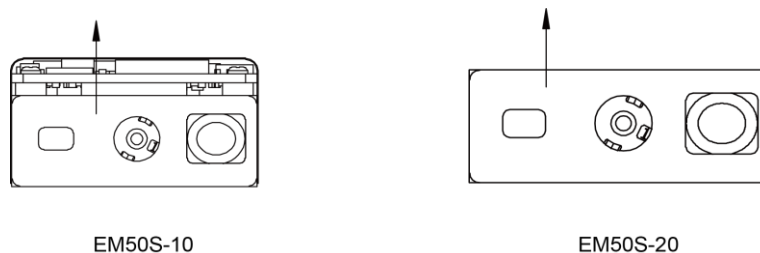

Figure 2-1

Mechanical Mounting Dimensions for EM50S-20 (Unit: mm)

Imager

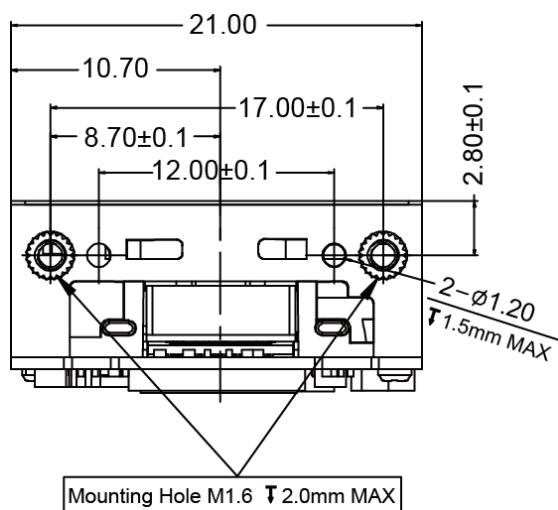
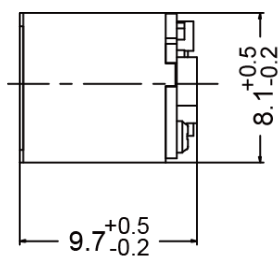
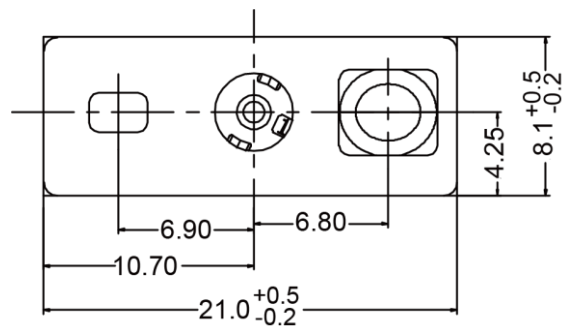

Figure 2-3

Decoder Board

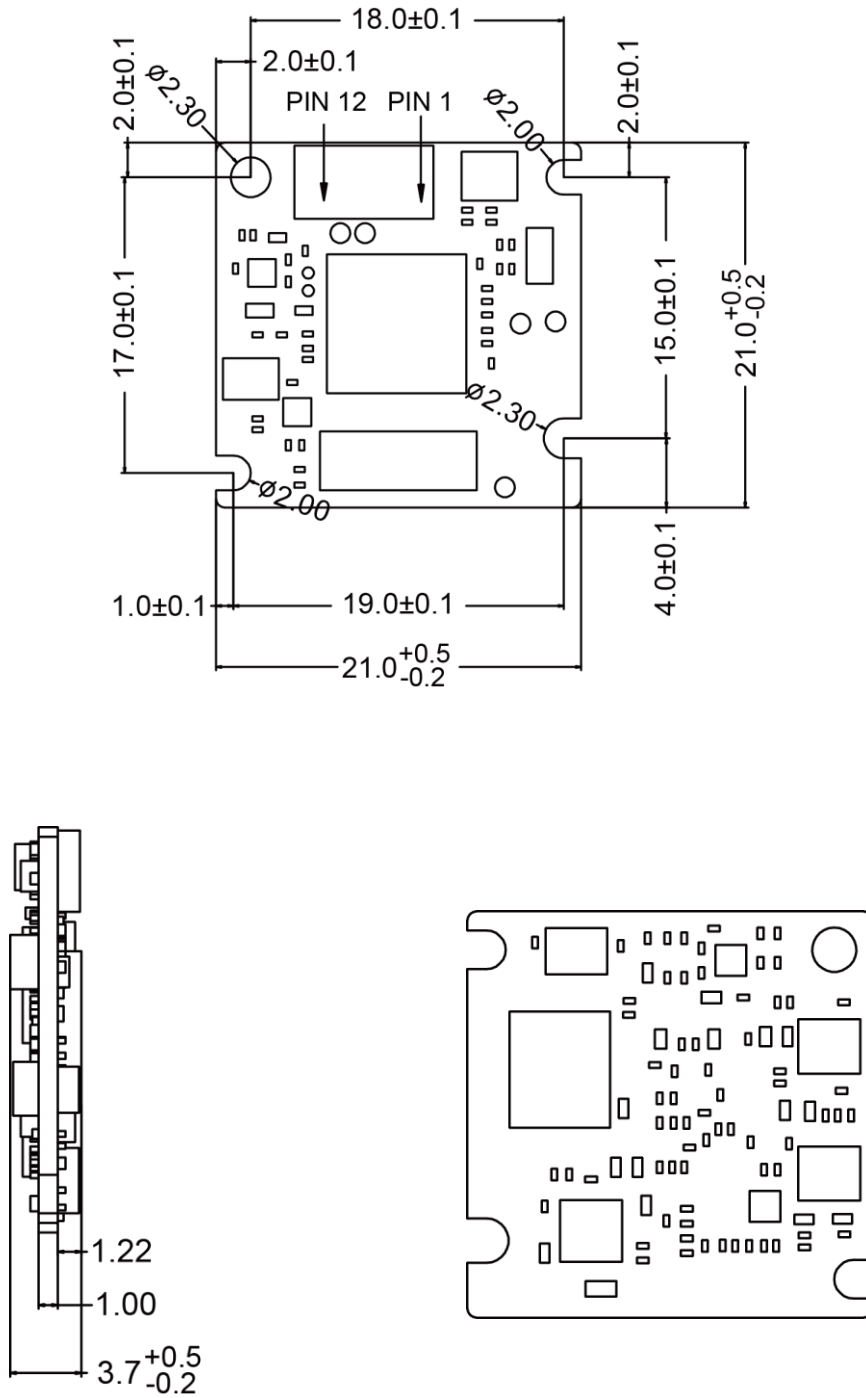

Figure 2-4

FPC Cable

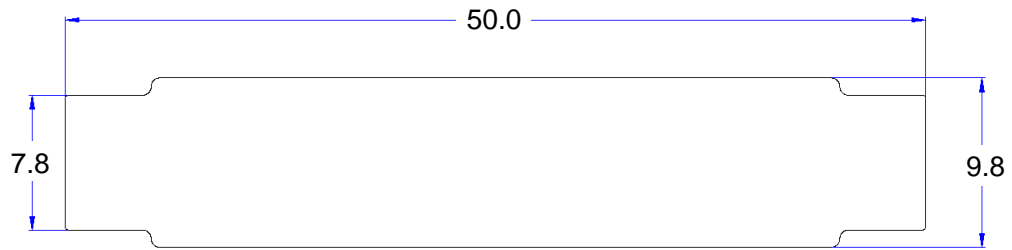

Figure 2-5

Installation of FPC Cable

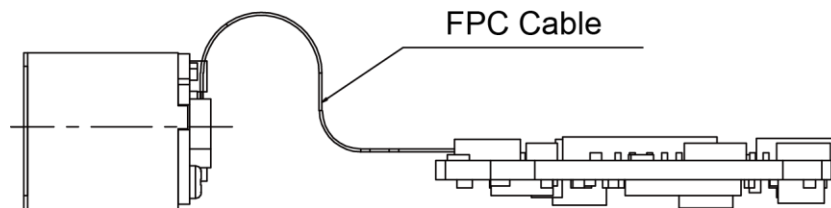
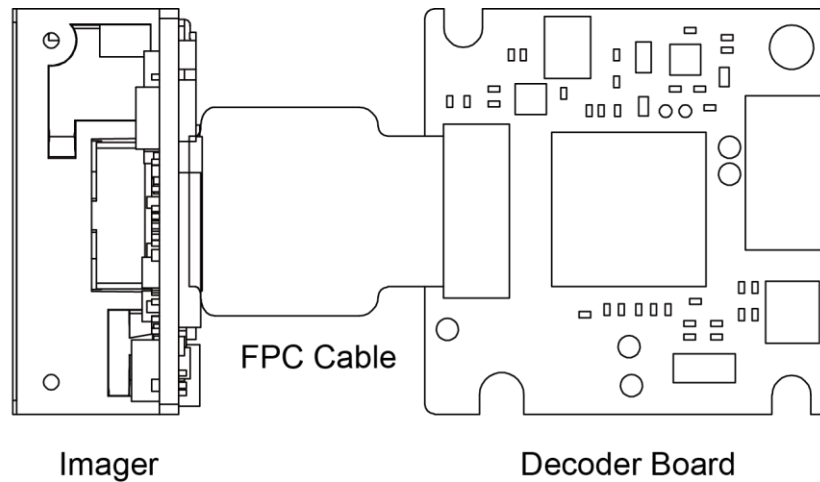

Figure 2-6

Table 2-3

Minimum Angle (Tilted Window)	Distance from the front of the engine housing (b)			
	5mm	10mm	15mm	20mm
Uncoated, minimum window positive tilt (+w)	22°	20°	18°	18°
Uncoated, minimum window negative tilt (-w)				
Anti-reflection coated, single side, minimum window positive tilt (+w)	20°	18°	16°	16°
Anti-reflection coated, single side, minimum window negative tilt (-w)				
Anti-reflection coated, double sides, minimum window positive tilt (+w)	16°	16°	16°	16°
Anti-reflection coated, double sides, minimum window negative tilt (-w)				

Window Material and Color

Window material must be clear. Use only cell-cast plastics or optical glass. PMMA, ADC and chemically tempered glass are recommended. Window material selected for the engine should meet or exceed the specifications specified in **Table 2-4**.

- **PMMA (Cell-cast acrylic):** When fabricated by cell-casting, has very good optical quality and low initial cost, but surface must be protected from the environment due to its susceptibility to attack by chemicals, mechanical stresses, and UV light. Reasonably good impact resistance. This material can be laser-cut into odd shapes and ultrasonically welded.
- **ADC (CR-39):** A thermal-setting plastic produced by the cell-casting process. Excellent chemical and environmental resistance. Quite good surface hardness, and therefore does not have to be hard-coated. Reasonably good impact resistance. This material cannot be ultrasonically welded.
- **Chemically tempered glass:** Glass is a hard material which provides excellent scratch and abrasion resistance. But unannealed glass is brittle. Increased flexibility strength with minimal optical distortion requires chemical tempering. Glass is hard to be cut into odd shapes and cannot be ultrasonically welded.

Table 2-4

Specification	Description
Spectral Transmittance	≥90%
Thickness	0.8-2.0mm
Wavefront Distortion	PV maximum: 0.2λ RMS maximum: 0.04λ
Clear Aperture	1.0mm to edges
Surface Quality	60-20 scratch/dig

Pay extra attention to the wavefront distortion when using plastic materials. Plastic materials are not recommended for tilted windows; colored windows are not recommended if the engine is used to scan barcodes on moving objects.

Coatings and Scratch Resistance

Scratch on the window can greatly reduce the performance of the EM50S. It is suggested to use recessed window or apply abrasion resistant coatings to window surface.

The following introduces two commonly-used types of coatings:

- **Anti-reflection coatings:** Anti-reflection (AR) coatings can be applied to window surfaces to reduce reflected light from the window back into the engine. But they are expensive and have poor abrasion/scratch resistance.
- **Polysiloxane coatings:** Polysiloxane coatings can be applied to plastic surfaces to increase the surfaces' abrasion and scratch resistance.

Both tempered glass and plastic windows can be AR coated. However, it is easier and more cost-effective to put an AR coating on the glass than on the plastic.

The AR coating specifications below should be met when using an AR coated window.

Single side AR coating: 92% minimum transmittance within spectrum range from 420 nm to 730 nm.

Double side AR coating: 97% minimum transmittance within spectrum range from 420 nm to 730 nm.

Window Size

The window must not block the field of view and should be sized to accommodate the aiming and illumination envelopes shown below.

EM50S-10

Horizontal:

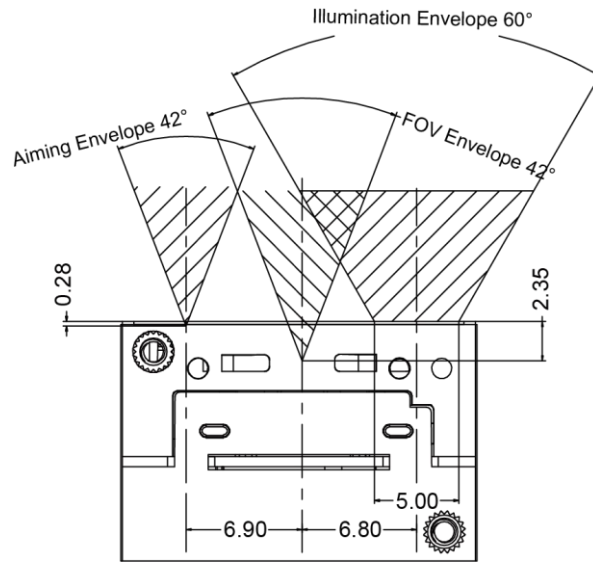

Vertical:

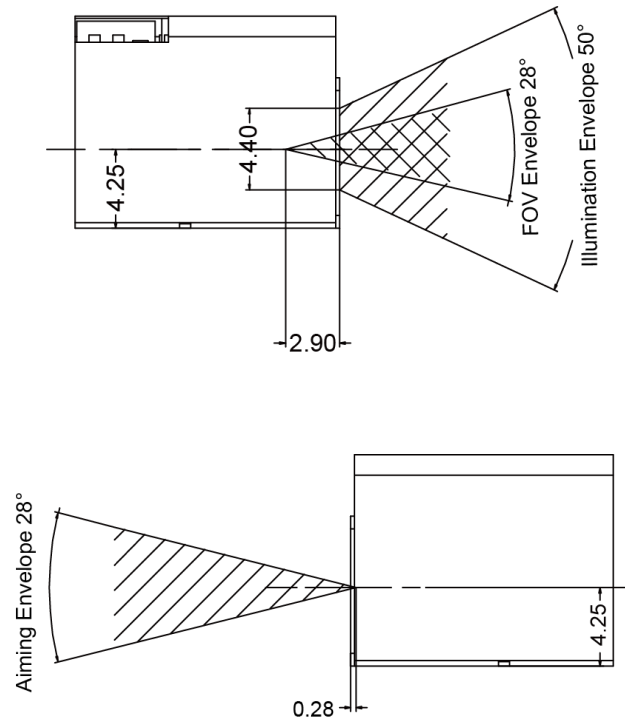
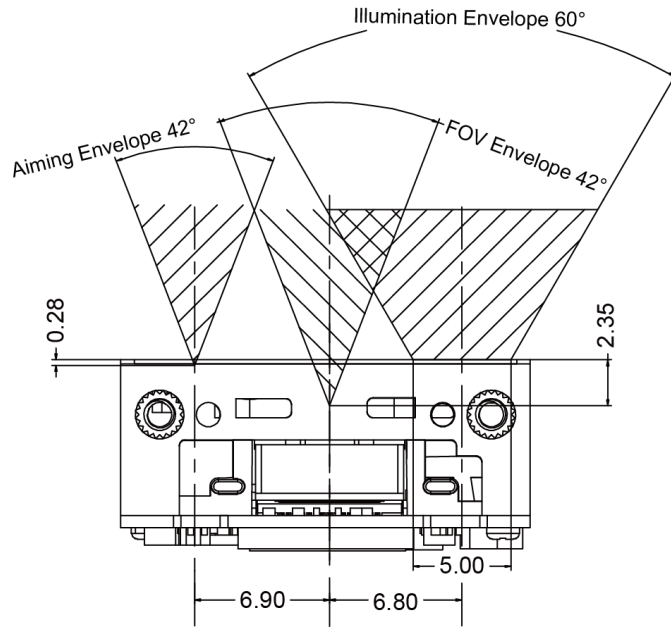

Figure 2-8

EM50S-20

Horizontal:



Vertical:

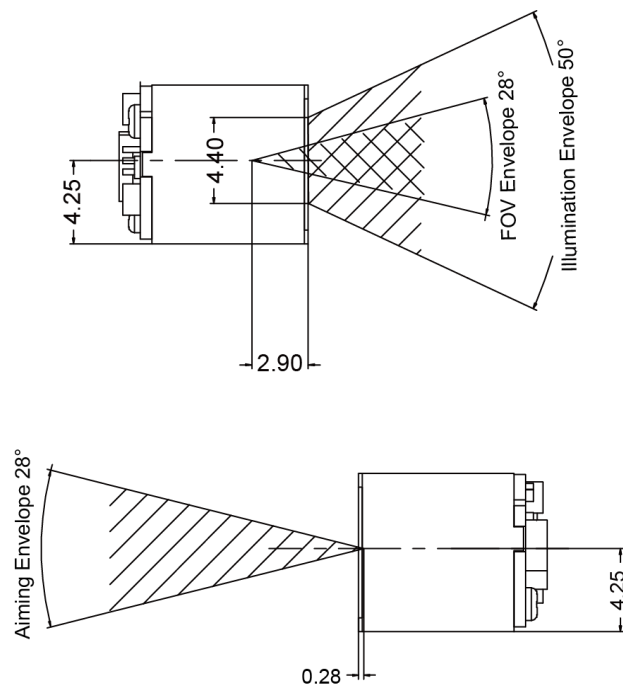

Figure 2-9

Roll, Skew and Pitch

Three different reading angles, roll, skew and pitch are illustrated in **Figure 2-10**. Roll refers to rotation around the Z axis, skew to rotation around the X axis and pitch to rotation around the Y axis. For the engine's technical specifications, please visit the Newland website or contact your dealer.

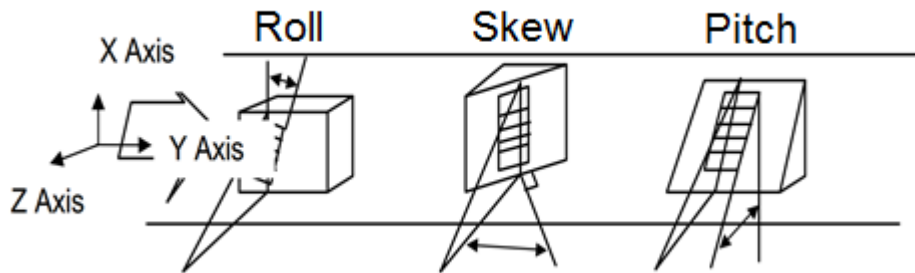

Figure 2-10

Ambient Light

The EM50S shows better performance with ambient light. However, high-frequency pulsed light can result in performance degradation.

Eye Safety

The EM50S uses LEDs to produce illumination beam. The LEDs are bright, but testing has been done to demonstrate that the engine is safe for its intended application under normal usage conditions. However, the user should avoid looking into the beam.

The EM50S uses a laser diode to form a bright, intuitive aiming aid. This device has been tested and found to comply with the limits for a Class 1 laser product, pursuant to Safety of laser products - Part 1: Equipment classification and requirements of IEC 60825-1:2014. A class 1 laser is safe under all conditions of normal use.

Chapter 3 Electrical Specifications

Power Supply

Do not power up the EM50S until it is properly connected. Be sure the power is cut off before connecting a cable to or disconnecting a cable from the host interface connector. Hot-plugging could damage the engine.

Unstable power supply or sharp voltage drops or unreasonably short interval between power-ons may lead to unstable performance of the engine. Do not resupply the power immediately after cutting it off.

Ripple Noise

To ensure the image quality, a power supply with low ripple noise is needed.

Acceptable ripple range (peak-to-peak): $\leq 80\text{mV}$

DC Characteristics

Operating Voltage / Current

Table 3-1

T=23°C

Parameter	Description	Minimum	Typical	Maximum	Unit
Operating Voltage	VIN (12-pin FPC Connector)	3.135	3.3	3.465	V
Current (@3.3V)	Operating Current	-	269 (RMS)	600 (PKPK)*	mA
	Idle Current	-	60	72	mA
	Sleep Current			1	mA

Note:

* 600mA (PKPK) is the peak current draw when the engine is scanning with the illumination set to Always On. To ensure the engine performance, it is imperative that the power supply can provide a minimum current of 600mA, but preferably 1A.

The user may put the engine into Sleep mode by sending the command **7E 00 00 09 7E 53 54 41 4E 44 42 59 7E A1** to it through serial interface, USB HID Keyboard, USB CDC COM, or USB HID-POS. To awake the engine from sleep mode, simply press the trigger.

I/O Voltage

Table 3-2

VDD=3.3 V, VSS=0 V, T=23°C

Parameter	Minimum	Maximum	Unit
VIL	VSS	0.8	V
VIH	2.0	VDD	V
VOL	VSS	0.4	V
VOH	2.4	VDD	V

Timing Sequence

Power Up and Power Down Timing Sequence

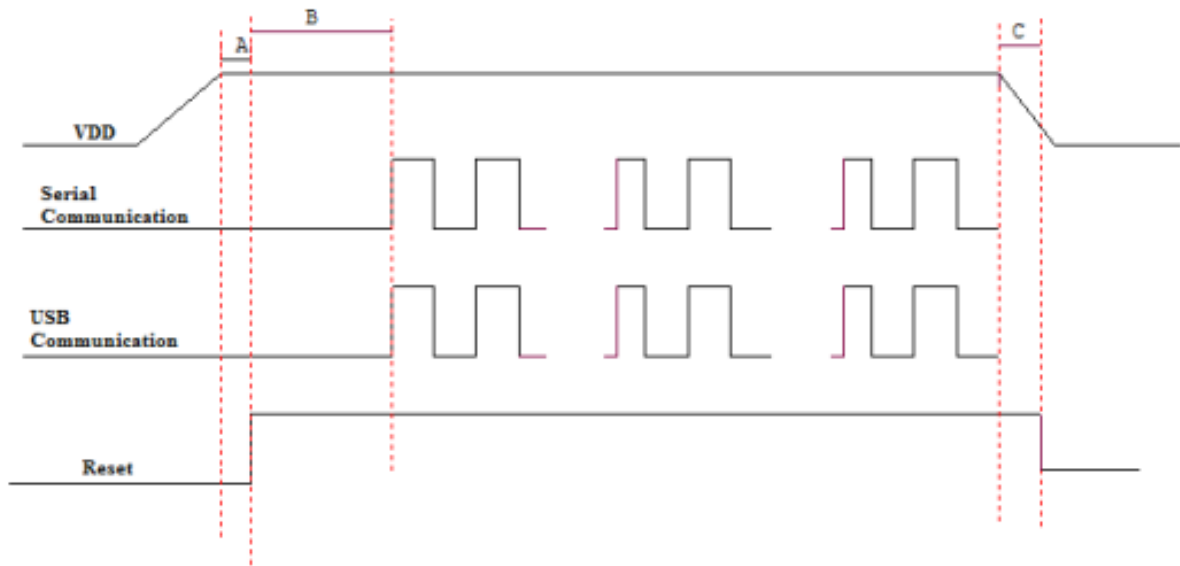

Figure 3-1

1. In the diagram above, it takes **A+B** (less than 1s) for the engine to power up: **A** is reset time (about 560ms), **B** is time needed to start the engine (including bootloader execution, kernel boot and decoding chip initialization). The engine is ready to receive commands via its serial/USB port after the power-up sequence completes.
2. **C** is the time it takes to power down the engine (during power-down, all voltages in the engine ramp down, with all communication stopped and all signals at a low level). To ensure that all voltages are fully down and signals on the interfaces at a low level, the minimum interval between removing and resupplying the power must exceed 2s.

Chapter 4 Interfaces

Interface Pinouts

The host interface connector of the EM50S is a 12-pin FPC connector, which can be used as TTL-232 interface or USB interface.

The figure below illustrates the position of 12-pin FPC connector on the EM50S's decoder board, as well as the pin 1 location.

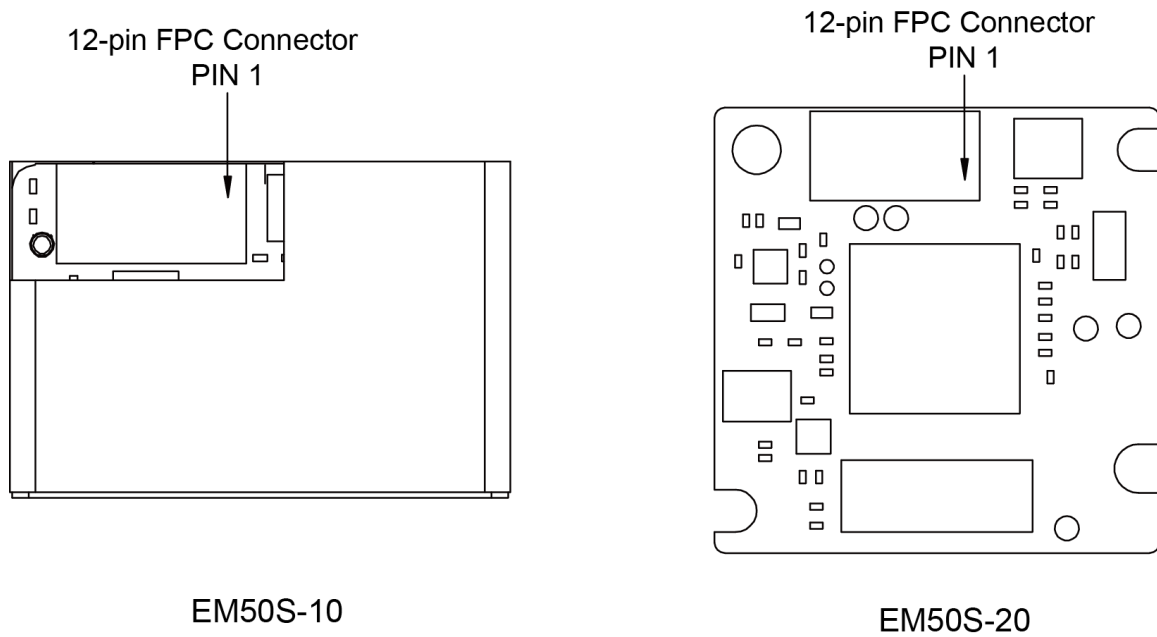

Figure 4-1

12-pin FPC Connector

The following table lists the pin functions of the 12-pin FPC connector.

Table 4-1

PIN#	Signal	I/O	Function	Remark
1	PIN1	-	No connection	
2	VIN	-	3.3V power supply input	
3	GND	-	Power-supply ground	
4	RXD	I	TTL level 232 receive data	
5	TXD	O	TTL level 232 transmit data	
6	USB_D-	I/O	USB D- differential data signal	
7	USB_D+	I/O	USB D+ differential data signal	
8	OUT_LIGHT_EN	-	External illumination control Default: disable (external illumination Off), input with $\geq 20K$ ohm pull up	See Note 1
9	BUZ	O	Beeper output	See Note 2
10	LED	O	Good Read LED output	See Note 3
11	nRESET	I	Reset signal input: active low	See Note 4
12	nTRIG	I	Trigger signal input: active low	See Note 5

※ I = Input; O = Output

※ 1 The OUT_LIGHT_EN signal (PIN 8) can be used to turn on external illumination LED when configured as an output. To program the external illumination On or Off, please see the EM50S user guide.

For the external illumination LED circuit design, please see the “External Illumination LED Circuit” section in this chapter. If the OUT_LIGHT_EN pin is not used, leave it unconnected.

※ 2 This output signal can be used by an external beeper circuit to generate audible feedback to the user to indicate power-on and good read statuses.

Power On beep: The BUZ pin (PIN 9) produces a PWM output (duration: 400ms; frequency: 4184Hz, both parameters are **NOT** user-programmable) 970ms after power-on. The beep can be programmed On or Off. To learn how to program the parameter, please see the EM50S user guide.

Good Read beep: The BUZ pin (PIN 9) produces a PWM output (default duration: 80ms; default frequency: 2730Hz, both parameters are user-programmable) when a good read occurs. The beep can be programmed On or Off. To learn how to program these parameters, please see the EM50S user guide.

For the external beeper circuit design, please see the “Beeper Circuit” section in this chapter. If the BUZ pin is not used, leave it unconnected.

※ 3 This output signal can be used by an external LED to indicate good read status.

The LED pin (PIN 10) produces a low output (default duration: 20ms, user-programmable) when a good read occurs. The Good Read LED can be programmed On or Off. To learn how to program these parameters, please see the EM50S user guide.

For the external LED circuit design, please see the “Good Read LED Circuit” section in this chapter. If the LED pin is not used, leave it unconnected.

※ 4 Giving a 200 μ s low pulse on the nRESET pin (PIN 11) will reset the engine. Normally this pin should be asserted high or in a high impedance state (there is a weak pull-up in the engine).

For the external reset circuit, please see the “Reset Circuit” section in this chapter. If the nRESET pin is not used, leave it unconnected.

※ 5 This external trigger signal can be either level trigger or pulse trigger.

Level trigger: A trigger pull (i.e. driving the nTRIG pin low for over 20ms) activates a decode session. The decode session continues until a barcode is decoded or the trigger is released.

Pulse trigger: When the trigger is pulled and released (pulse width : 50ms), scanning is activated until a barcode is decoded or the decode session timeout expires.

For the external trigger circuit, please see the “Trigger Circuit” section in this chapter. If the nTRIG pin is not used, leave it unconnected.

Connector/Cable Specifications (Unit: mm)

The EM50S is equipped with a 12-pin FPC connector.

12-pin FPC Connector

The 12-pin FPC connector on the EM50S is supplied by Hirose Electric Co., Ltd. Model No.: FH34SRJ-12S-0.5SH(50), dual contact.

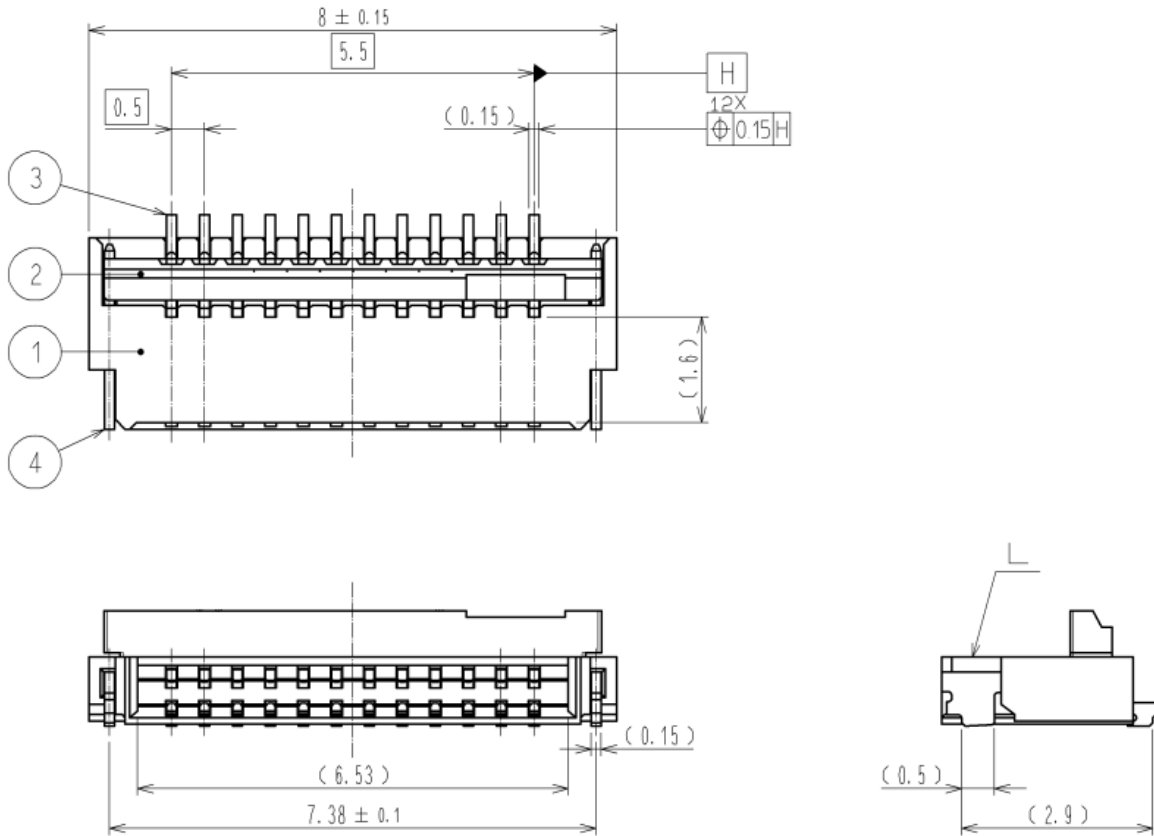

Figure 4-2

12-pin FFC Cable

A 12-pin cable can be used to connect the engine's 12-pin FPC connector to a host device.

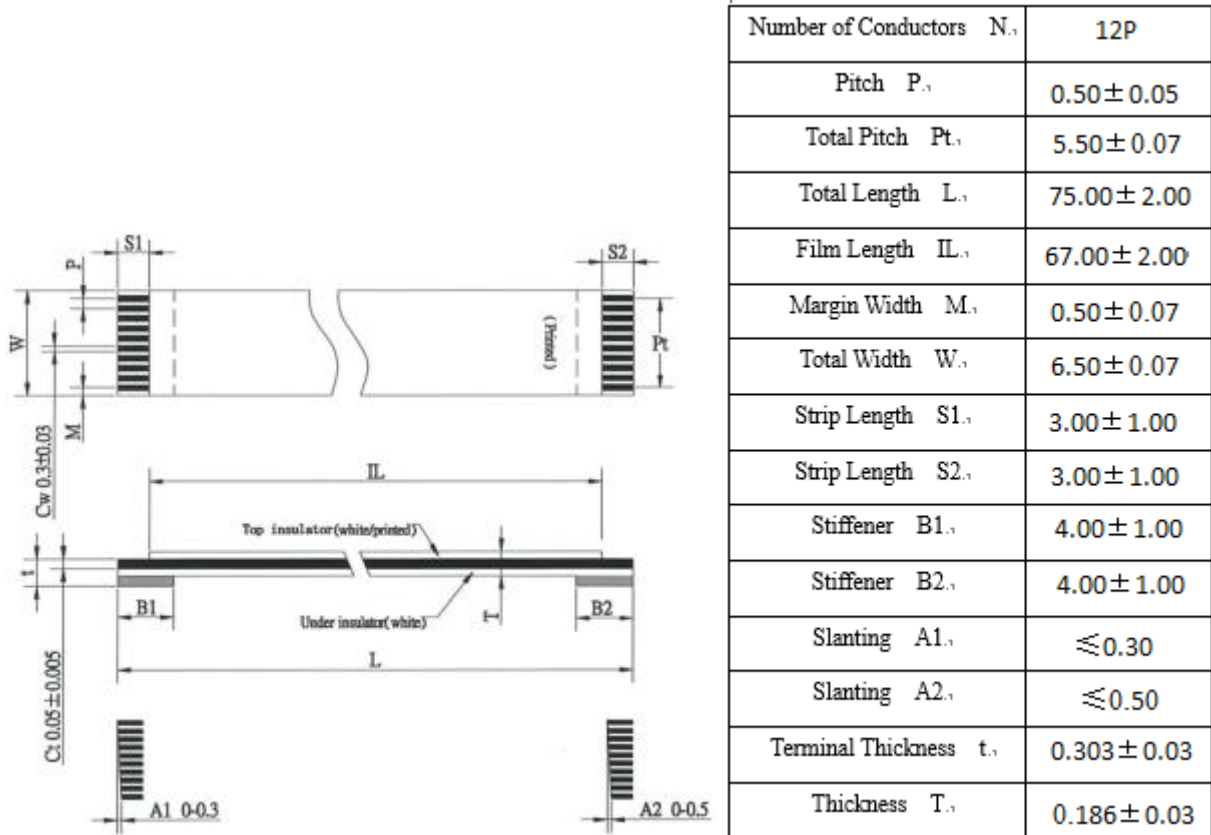

Figure 4-3

External Circuit Design

Good Read LED Circuit

The circuit below can be used to drive an external LED for indicating good read. The LED signal is from PIN 10 of the 12-pin FPC connector.

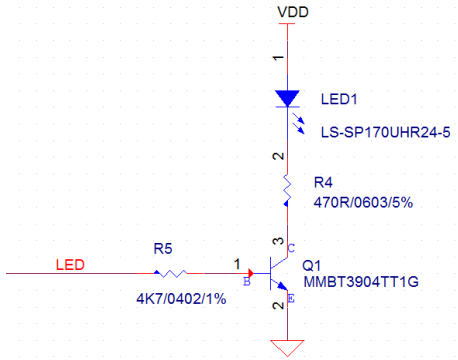

Figure 4-4

Beeper Circuit

The circuit below can be used to drive an external beeper. The BUZ signal is from PIN 9 of the 12-pin FPC connector.

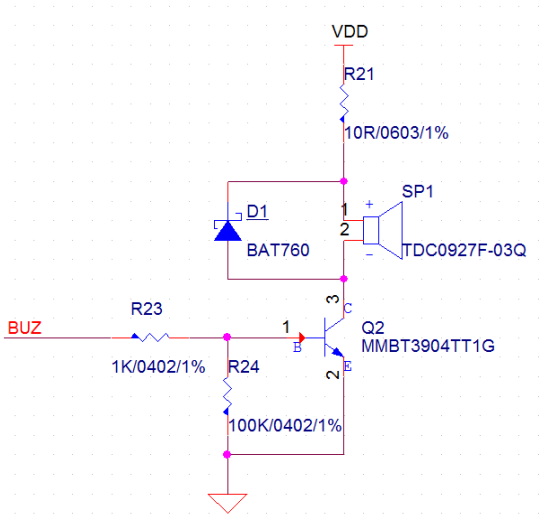

Figure 4-5

Trigger Circuit

The circuit below can be used to provide the engine with a signal to trigger a scan and decode session. The nTRIG signal is from PIN 12 of the 12-pin FPC connector.

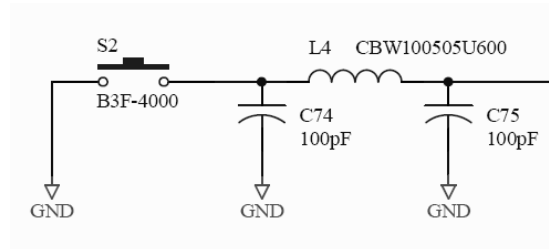

Figure 4-6

External Illumination LED Circuit

The circuit below can be used to control external illumination LED when the user wants to add external illumination to further improve lighting. It is recommended that the time it takes to power up the circuit be shorter than 100 μ s. The OUT_LIGHT_EN signal is from PIN 8 of the 12-pin FPC connector.

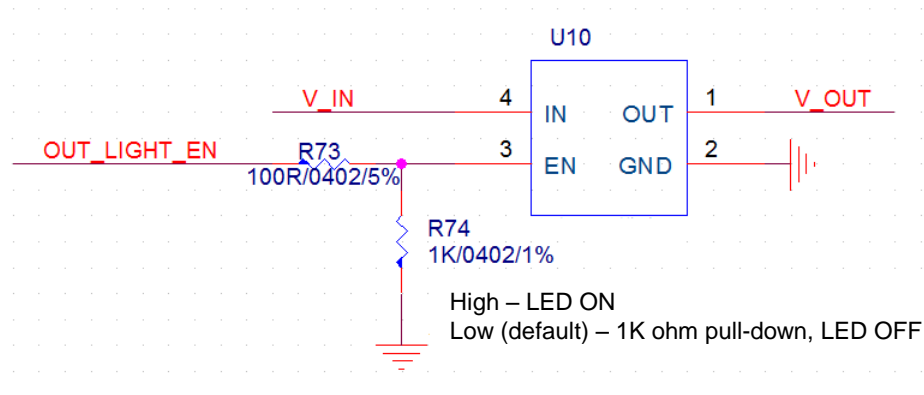

Figure 4-7

Reset Circuit

The circuit below can be used to reset the engine by giving a 200 μ s low pulse on the nRESET pin (PIN 11) on the host interface. The host device can send the RESET signal through GPIO.

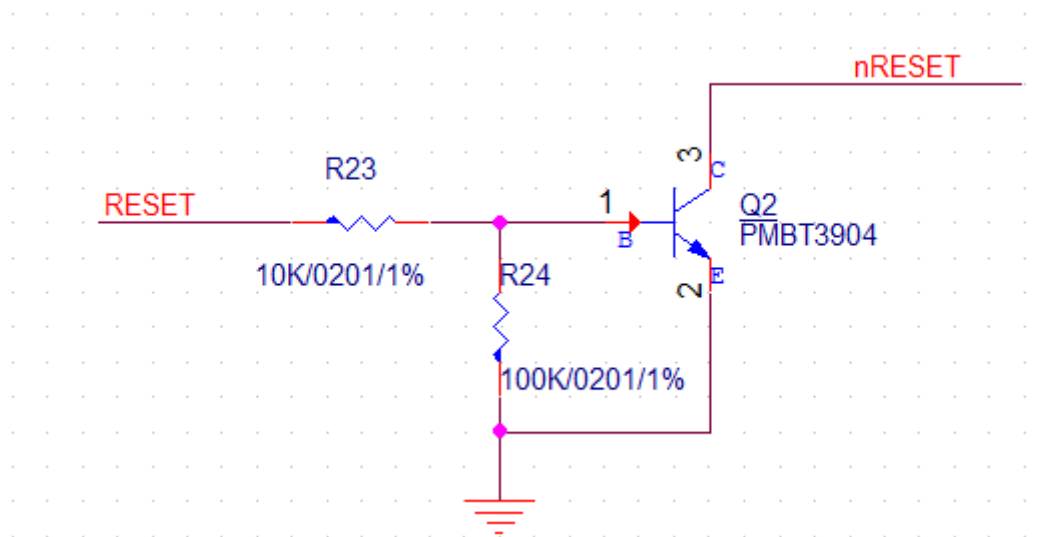

Figure 4-8

Chapter 5 Auxiliary Tools

The EM50S provides the following two tools to assist users in engine performance evaluation, application development and engine configuration.

EVK

The EVK is provided to help users to test and evaluate the EM50S, which contains beeper & beeper driver circuit, LED & LED driver circuit, and trigger & reset buttons, TTL-232 to RS-232 converter & TTL-232 to USB converter, RS-232 & USB interfaces, etc. The EM50S can be connected to the EVK via a 12-pin FFC cable type 1 (contacts on the same side). Either USB connection or RS-232 connection can be used when connecting the EVK to a host device.

EasySet

EasySet is a Windows-based configuration tool developed by Newland, which can be used to configure the EM50S.



Newland EMEA HQ

+31 (0) 345 87 00 33
info@newland-id.com
newland-id.com

D-A-CH

0049 (0) 6182 82916-16
info@newland-id.de

United Kingdom

+44 (0) 7771 631387
sales@newland-id.co.uk

France

+39 (0) 345 8804096
france@newland-id.com

Russia

+31 (0) 345 87 00 33
russia@newland-id.com

Benelux

+31 (0) 345 87 00 33
benelux@newland-id.com

South Africa

Gauteng: +27 (0) 11 553 8010
Cape Town: +27 (0) 21 9140819
info@newland-id.co.za

Ibérica

+34 (0) 93 303 74 66
info@newland-id.es

Middle East

+39 (0) 345 8804096
middleeast@newland-id.com

Italy

+39 (0) 342 0562227
italy@newland-id.com

Turkey

+90 (0) 544 538 40 49
turkey@newland-id.com

Nordic & Baltic

+46 (0) 70 88 47 767
nordic@newland-id.com