



Newland

SCANNING MADE SIMPLE



N1 OEM scan engine integration guide

Disclaimer

© 2020 Fujian Newland Auto-ID Tech. Co., Ltd. All rights reserved.

Please read through the manual carefully before using the product and operate it according to the manual. It is advised that you should keep this manual for future reference.

Do not disassemble the device or remove the seal label from the device, doing so will void the product warranty provided by Fujian Newland Auto-ID Tech. Co., Ltd.

All pictures in this manual are for reference only and actual product may differ. Regarding to the product modification and update, Fujian Newland Auto-ID Tech. Co., Ltd. reserves the right to make changes to any software or hardware to improve reliability, function, or design at any time without notice. The information contained herein is subject to change without prior notice.

The products depicted in this manual may include software copyrighted by Fujian Newland Auto-ID Tech. Co., Ltd or third party. The user, corporation or individual, shall not duplicate, in whole or in part, distribute, modify, decompile, disassemble, decode, reverse engineer, rent, transfer or sublicense such software without prior written consent from the copyright holders.

This manual is copyrighted. No part of this publication may be reproduced, distributed or used in any form without written permission from Newland.

Fujian Newland Auto-ID Tech. Co., Ltd. reserves the right to make final interpretation of the statement above.

Fujian Newland Auto-ID Tech. Co., Ltd.

3F, Building A, No.1, Rujiang West Rd., Mawei, Fuzhou, Fujian, China 350015

<http://www.newlandaidc.com>

Revision History

| Version | Description | Date |
|---------|--|----------------|
| V1.0.0 | Initial release. | March 13, 2020 |
| V1.0.1 | Updated Figure 2-1, Figure 2-2 and Figure 5-3. | April 08, 2020 |

Table of Contents

| | |
|---|--------------|
| Revision History | - 3 - |
| About This Guide..... | 1 |
| Introduction..... | 1 |
| Chapter Description..... | 1 |
| Explanation of Symbols | 1 |
| Chapter 1 Getting Started | 2 |
| Introduction..... | 2 |
| Illumination | 3 |
| Aimer | 3 |
| Chapter 2 Installation | 4 |
| Introduction..... | 4 |
| General Requirements | 4 |
| ESD | 4 |
| Dust and Dirt..... | 4 |
| Ambient Environment..... | 4 |
| Thermal Considerations..... | 5 |
| External Optical Elements..... | 5 |
| Mounting..... | 6 |
| Housing Design | 6 |
| Optics | 7 |
| Window Placement | 7 |
| Window Material and Color | 8 |
| Coatings and Scratch Resistance | 9 |
| Window Size | 9 |
| Roll, Skew and Pitch | 11 |
| Ambient Light | 11 |
| Eye Safety | 11 |
| Chapter 3 Interfaces | 12 |
| Interface Pinouts | 12 |
| 13-pin FPC Connector | 12 |
| Connector Specifications | 15 |
| Chapter 4 Electrical Specifications..... | 16 |

| | |
|---|-----------|
| Power Supply | 16 |
| Ripple Noise | 16 |
| DC Characteristics | 16 |
| Operating Voltage | 16 |
| Operating Current | 16 |
| I/O Voltage | 19 |
| Timing Sequence..... | 20 |
| Power Up Timing Sequence | 20 |
| Power Down Timing Sequence | 22 |
| Chapter 5 Interfaces | 23 |
| External Circuit Design | 23 |
| Good Read LED Circuit | 23 |
| Beeper Circuit | 24 |
| Trigger Circuit | 24 |
| External Illumination Control Circuit | 25 |
| Chapter 6 Auxiliary Tools..... | 26 |
| EVK | 26 |
| EasySet..... | 26 |

About This Guide

Introduction

The NLS-N1 OEM scan engines (hereinafter referred to as “the N1” or “the engine”) are armed with CMOS image capturer and the Newland patented **UIMG[®]**, a computerized image recognition system-on-chip, featuring fast scanning and accurate decoding on barcodes on virtually any medium-paper, mobile phones and merchandise. The N1 can be easily integrated into OEM equipment, such as wearable and pocket barcode scanners.

※ Note: This guide provides general instructions for the installation of the engine into a customer's device. Fujian Newland Auto-ID Tech. Co., Ltd. recommends an opto-mechanical engineer should conduct an opto-mechanical analysis before integration.

Chapter Description

| | |
|---------------------------------------|---|
| Chapter 1, Getting Started | Gives a general description of the N1. |
| Chapter 2, Installation | Describes how to install the engine, including installation information, housing design, optical, grounding, ESD, and environmental considerations. |
| Chapter 3, Interfaces | Includes interface pinout and connector specifications. |
| Chapter 4, Electrical Specifications | Includes the electrical characteristics for the engine and timing sequences. |
| Chapter 5, External Reference Circuit | Provide external driver circuit diagrams. |
| Chapter 6, Auxiliary Tools | Introduces useful tools you can use to test and evaluate the N1 as well as conduct secondary development. |

Explanation of Symbols

- This symbol indicates lists of required steps.
- ※ This symbol indicates something important to the readers. Failure to read the notice will not lead to harm to the reader, device or data.
- ⚠ This symbol indicates caution that, if ignored, may cause data or device damage or even personal injury.

Chapter 1 Getting Started

Introduction

The N1 includes an aiming LED and an illumination LED.

LED Compliance Statement

The N1 complies with IEC 62471:2006 for LED safety.

The N1 contains:

- a CMOS image sensor and its lens
- an LED based illumination system
- an LED aiming system

Figure 1-1 System Block Diagram

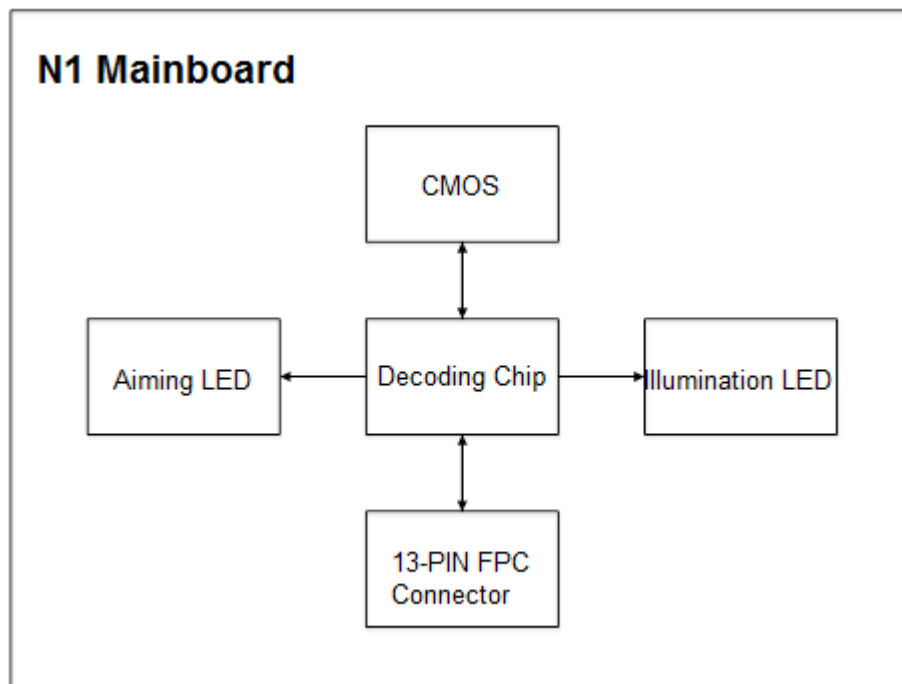

The N1 can be connected to a host device via its 13-pin FPC connector. For more information about this connector, please see Chapter 3.

Illumination

The N1 has a white LED for supplementary lighting, making it possible to scan barcodes even in complete darkness. The illumination can be programmed On or Off.

When customer designing the external illumination system:

- Avoid reflections back into the engine, which will lead to poor reading performance.
- Ensure the uniformity of illumination within the field of view.
- Customers can set the external illumination system as Always On mode. If the PWM mode is required, please contact Newland to customize the software.
- LED is recommended as light source for the external illumination system. Please refer to the quantum yield of sensor (see figure 1-2) when selecting spectrum.

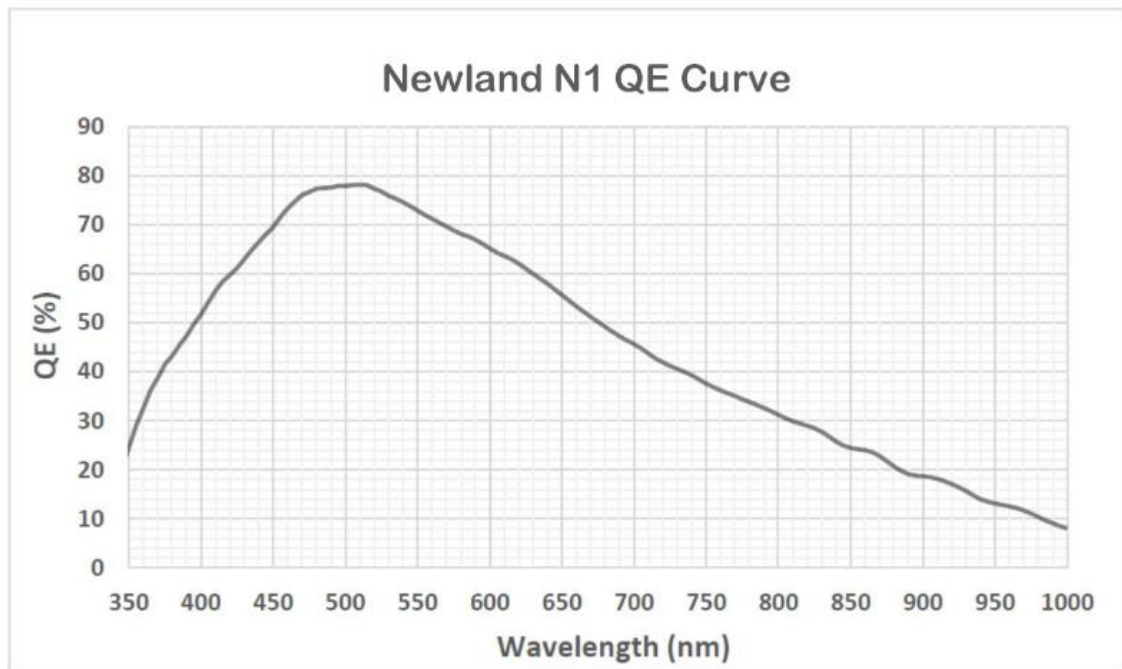

Figure 1-2

Aimer

The N1 contains a red LED aimer to help the user to easily position the target barcode within the engine's field of view to increase scan efficiency. The aiming pattern can be turned On or Off. It is advisable to turn it on when scanning barcodes in regular circumstances. For applications in the background of different materials and colors or in the strong light or backlight environment, it is advised to turn off the aimer.

Chapter 2 Installation

Introduction

This chapter explains how to install the N1, including general requirements, housing design, and physical and optical information.

⚠ Caution: Do not touch the imaging lens when installing the engine. Be careful not to leave fingerprints on the lens.

⚠ Caution: Do not touch the illumination LED during handling. Improper handling may damage the LED.

General Requirements

ESD

ESD protection has been taken into account when designing the N1. However, due to limited board space, additional ESD protection, such as TVS protection, is not provided on the engine's I/O interface. It is advised to take corresponding protection measures when integrating the engine.

The engine is shipped in ESD safe packaging. Always exercise care when handling the engine outside its package. Be sure grounding wrist straps and properly grounded work areas are used.

Dust and Dirt

The N1 must be sufficiently enclosed to prevent dust particles from gathering on the lens and circuit board. Dust and other external contaminants will eventually degrade the engine's performance.

Ambient Environment

The following environmental requirements should be met to ensure good performance of the N1.

Table 2-1

| | |
|-----------------------|--------------------------|
| Operating Temperature | -20°C to 55°C |
| Storage Temperature | -40°C to 70°C |
| Humidity | 5% ~95% (non-condensing) |

Thermal Considerations

Electronic components in the N1 will generate heat during the course of their operation. Operating the N1 in continuous mode for an extended period may cause temperatures to rise on CPU, CIS, LEDs, DC-DC, etc. Overheating can degrade image quality and affect scanning performance. Given that, the following precautions should be taken into consideration when integrating the N1.

- ✧ Reserve sufficient space for good air circulation in the design.
- ✧ Avoid wrapping the N1 with thermal insulation materials such as rubber.

External Optical Elements

Do not subject external optical components on the engine to any external force. Do not hold the engine by an external optical component, which may cause the mechanical joints that secure the components to crack or break due to excessive stress.

Mounting

The illustrations below show the mechanical mounting dimensions (unit: mm) for the N1.

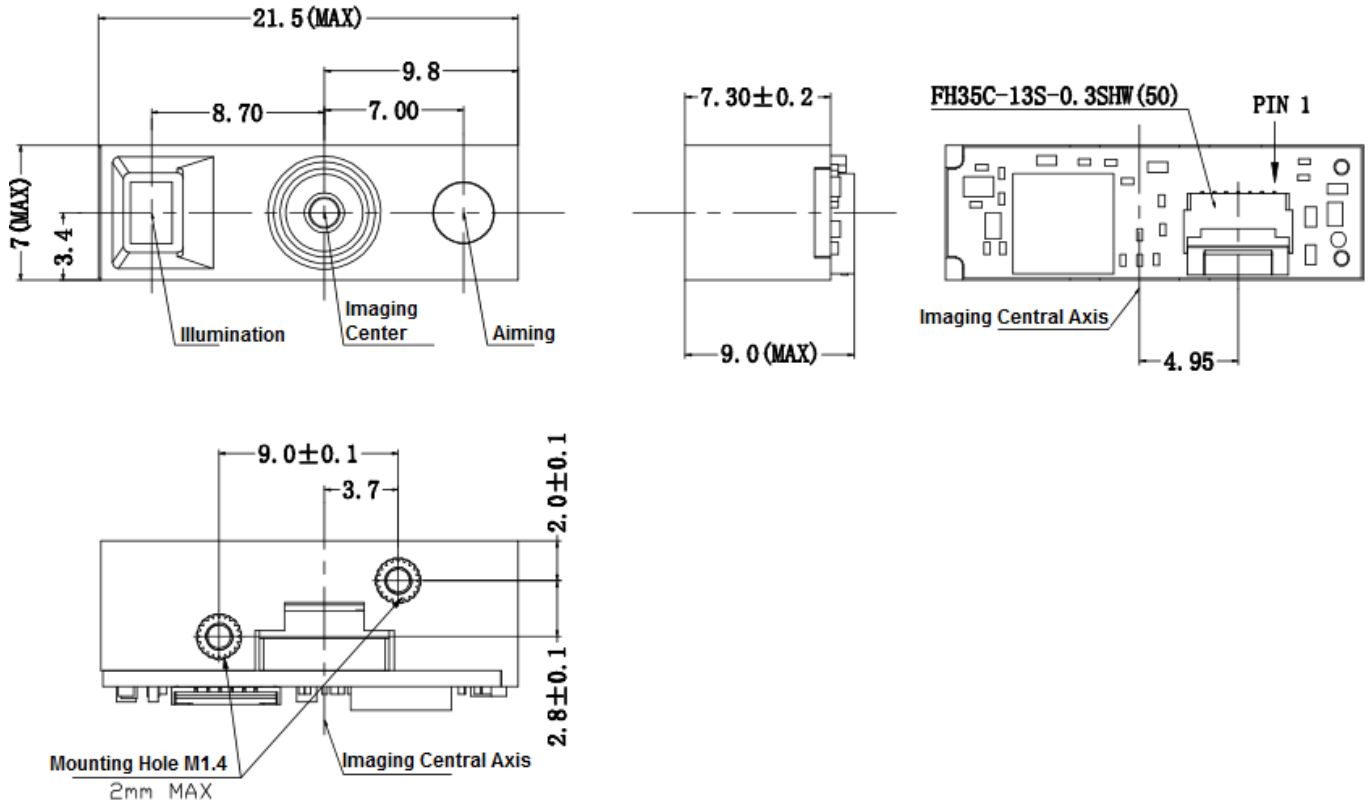

Figure 2-1

Note: Tolerance of dimension is $\pm 0.15\text{mm}$.

Housing Design

※ Note: Conduct an optical analysis for the housing design to ensure optimal scanning and imaging performance.

Housing design should make sure that internal reflections from the aiming and illumination system are not directed back to the engine. The reflections from the housing or window can cause problems. Avoid any highly reflective objects around the engine that can cause bright spots to appear in the captured image. It is recommended to use baffles or matte-finished dark internal housing colors.

Optics

The N1 uses a sophisticated optical system. An improperly designed internal housing or improper selection of window material can degrade the engine's performance.

Window Placement

The window should be positioned properly to let the illumination and aiming beams pass through as much as possible and no reflections back into the engine (reflections can degrade the reading performance of the engine).

There are two window placement options.

- **Parallel window** – Primary option for imager engines. The following window distance requirements should be satisfied: The maximum distance is measured from the front of the engine housing to the furthest surface of the window. In order to reach better reading performance, the distance from the front of the engine housing to the nearest surface of the window should not exceed **a** ($a=0.1\text{mm}$) and the distance from the front of the engine housing to the furthest surface of the window should not exceed **a+d** ($a=0.1\text{mm}$, $d=2\text{mm}$), as shown in **Figure 2-2**.
- **Tilted window** - This option is for laser/imager engines. For the tilted window distance requirements, please see **Table 2-2**.

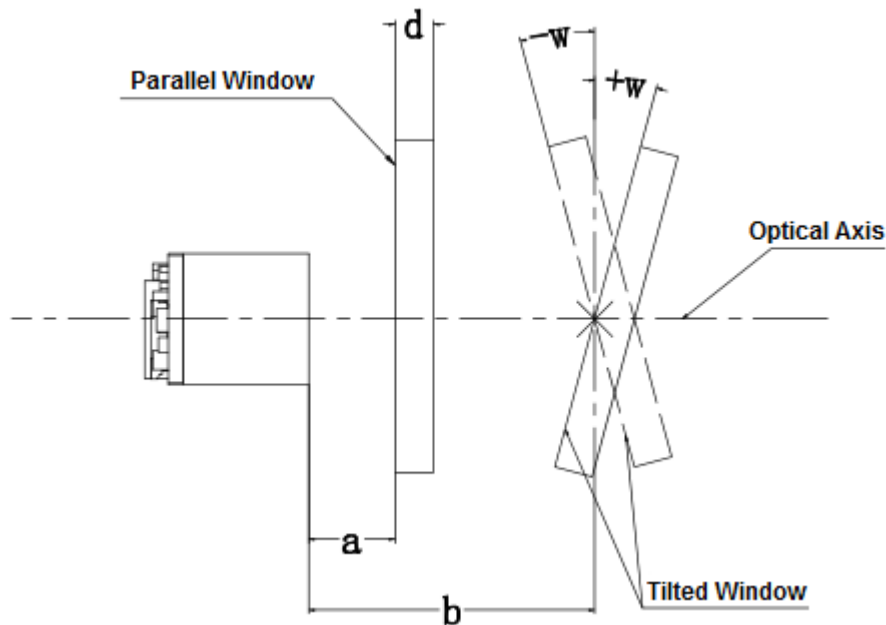

Figure 2-2

Table 2-2

| Minimum Angle (Tilted Window) | Distance from the front of the engine housing (b) | | |
|---|---|------|------|
| | 10mm | 15mm | 20mm |
| Uncoated, minimum window positive tilt (+w) | 35° | 30° | 28° |
| Uncoated, minimum window negative tilt (-w) | | | |

Window Material and Color

Window material must be clear. Use only cell-cast plastics or optical glass. PMMA and chemically tempered glass are recommended. Window material selected for the engine should meet or exceed the specifications specified in **Table 2-3**. When using a clear plastic window, it is recommended to apply anti-reflection (AR) coating on it.

- **PMMA (Cell-cast acrylic):** When fabricated by cell-casting, has very good optical quality and low initial cost, but surface must be protected from the environment due to its susceptibility to attack by chemicals, mechanical stresses, and UV light. Reasonably good impact resistance.
- **Chemically tempered glass:** Glass is a hard material which provides excellent scratch and abrasion resistance. But unannealed glass is brittle. Increased flexibility strength with minimal optical distortion requires chemical tempering. Glass is hard to be cut into odd shapes and cannot be ultrasonically welded.

Table 2-3

| Specification | Description |
|------------------------|----------------------------------|
| Spectral Transmittance | ≥90% (PMMA) |
| | ≥91% (Chemically tempered glass) |
| Thickness | 0.5-2.0mm |
| Light Wavelength | 400-780nm |
| Clear Aperture | 1.0mm to edges |
| Surface Quality | 60-20 scratch/dig |

Pay extra attention to the light wavelength when using plastic materials. Colored windows are not recommended if the engine is used to scan barcodes on moving objects.

Coatings and Scratch Resistance

Scratch on the window can greatly reduce the performance of the N1. It is suggested to use abrasion resistant window material or coating.

The following introduces two commonly-used types of coatings:

- **Anti-reflection coatings:** Anti-reflection (AR) coatings can be applied to window surfaces to reduce reflected light from the window back into the engine. Multi-layer AR coatings on windows help to achieve less than 0.5% reflectance and covered wavelength is 400-780nm.

- **Scratch resistance coatings:** Scratch resistance coatings require a degree of greater than 5H in its hardness. Coatings can be applied to plastic surfaces to increase the surfaces' abrasion and scratch resistance.

Both tempered glass and plastic windows can be AR coated. However, it is easier and more cost-effective to put an AR coating on the glass than on the plastic.

The AR coating specifications below should be met when using an AR coated window.

Single side AR coating: 93% minimum transmittance within spectrum range from 400 nm to 780 nm.

Double side AR coating: 97% minimum transmittance within spectrum range from 400 nm to 780 nm.

Window Size

The window must not block the field of view and should be sized to accommodate the aiming and illumination envelopes shown below.

Horizontal:

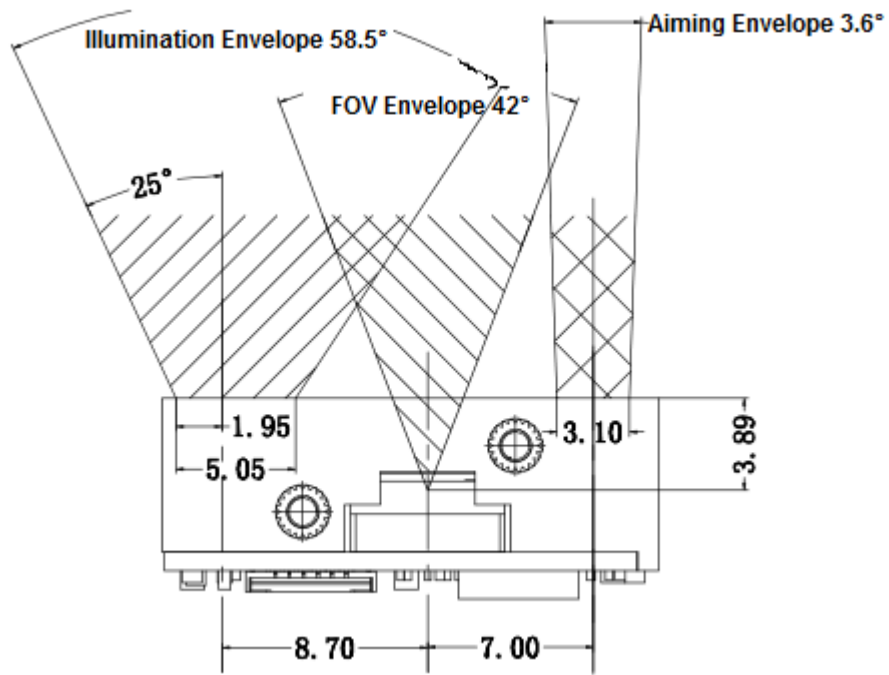

Figure 2-3

Vertical:

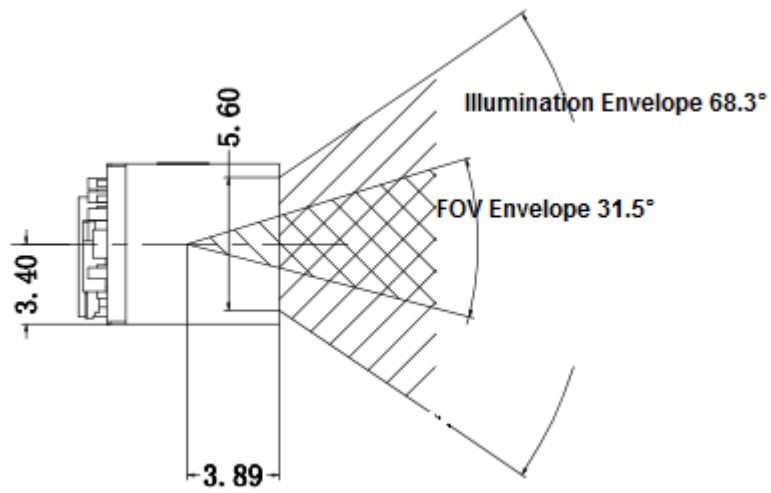

Figure 2-4

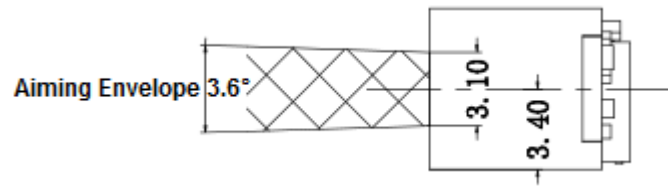

Figure 2-5

Roll, Skew and Pitch

Three different reading angles, roll, skew and pitch are illustrated in **Figure 2-6**. Roll refers to rotation around the Z axis, skew to rotation around the X axis and pitch to rotation around the Y axis. For the engine's technical specifications, please visit the Newland website or contact your dealer.

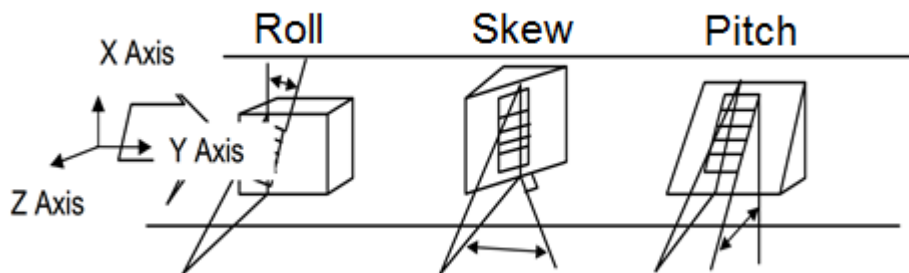

Figure 2-6

Ambient Light

The N1 shows better performance with ambient light. However, high-frequency pulsed light can result in performance degradation.

Eye Safety

The N1 has no lasers. It uses LEDs to produce illumination beam. The LEDs are bright, but testing has been done to demonstrate that the engine is safe for its intended application under normal usage conditions. However, the user should avoid looking into the beam.

Chapter 3 Interfaces

Interface Pinouts

The physical interface of the N1 consists of a 13-pin FPC connector:

- 13-pin FPC connector can be used as TTL-232 interface or USB interface.

The figure below illustrates the position of the connector on the N1, as well as the pin 1.

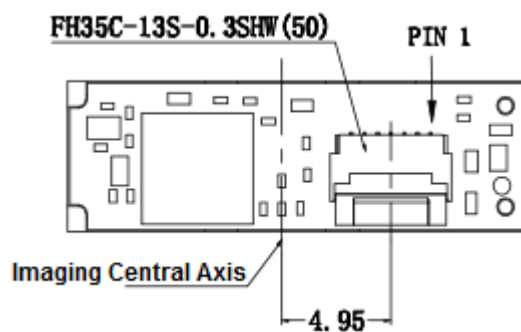

Figure 3-1

13-pin FPC Connector

The following table lists the pin functions of the 13-pin FPC connector.

Table 3-1

| PIN# | Signal | I/O | State | Function | Remark |
|------|--------------|-----|-------------|--------------------------------------|---|
| 1 | GND | - | - | Power-supply ground | |
| 2 | nTRIG | I | Pull-up | Trigger signal input | 100k pull-up (see Note 1) |
| 3 | nRST | I | Pull-up | Reset signal input | 4.7k pull-up (see Note 2) |
| 4 | LED | O | Pull-down | Good Read LED output | 100k pull-down (see Note 3) |
| 5 | BUZ | O | Pull-down | Beeper output | 10k pull-down (see Note 4) |
| 6 | Ext.LED.Ctrl | O | Unconnected | External illumination control signal | If the pin is not used, leave it unconnected. |
| 7 | USB_D+ | - | - | USB_D+ signal | |
| 8 | USB_D- | - | - | USB_D- signal | |
| 9 | TXD | O | - | TTL level 232 transmit data | |

| | | | | | |
|----|-----|---|---|----------------------------|--|
| 10 | RXD | I | - | TTL level 232 receive data | |
| 11 | GND | - | - | Power-supply ground | |
| 12 | VDD | - | - | 3.3V power input | |
| 13 | VDD | - | - | 3.3V power input | |

※ I = Input; O = Output; od = Open Drain;

※ 1 The nTRIG signal is not directly from the MCU pin, so high and low levels are different from other input and output interfaces. When designing the external control module, please refer to I/O Voltage in Table 4-3.

This external trigger signal can be either level trigger or pulse trigger.

Level trigger: A trigger pull activates a decode session. The decode session continues until a barcode is decoded or the trigger is released.

Pulse trigger: When the trigger is pulled and released (pulse width : 50ms), scanning is activated until a barcode is decoded or the decode session timeout expires. The duration can be programmed. To learn how to program the parameter, please see the N1 user guide.

For the external trigger circuit, please see the “Trigger Circuit” section in Chapter 5.

※ 2 Keep level low above 10ms to reset the engine. If this pin is not used, leave it unconnected.

※ 3 This output signal can be used by an external LED to indicate good read status.

The nGoodRead pin produces a high output (default duration: 20ms, user-programmable) when a good read occurs. The Good Read LED can be programmed On or Off. To learn how to program these parameters, please see the N1 user guide.

For the external LED circuit design, please see the “Good Read LED Circuit” section in Chapter 5. If the nGoodRead pin is not used, leave it unconnected.

※ 4 This output signal can be used by an external beeper circuit to generate audible feedback to the user to indicate power-on and good read statuses.

Power On beep: The nBEEPER pin produces a PWM output (duration: 400ms; frequency: 2090Hz, 2630Hz, 3130Hz and 4260Hz.) 215ms after power-on. The beep can be programmed On or Off. To learn how to program the parameter, please see the N1 user guide.

Good Read beep: The nBEEPER pin produces a PWM output (default duration: 80ms; default frequency: 2710Hz) when a good read occurs. The beep can be programmed On or Off. To learn how to program these parameters, please see the N1 user guide.

For the external beeper circuit design, please see the “Beeper Circuit” section in Chapter 5. If the nBEEPER pin is not used, leave it unconnected.

※ 5 Pin 6 is the external illumination control signal. For the external illumination control circuit design, please see the “External Illumination Control Circuit” section in Chapter 5. If the external illumination control signal pin is not used, leave it unconnected.

※ 6 To be compatible with other engines of our company, the 12-PIN connector is recommended below.

Table 3-2

12-pin connector

| PIN# | Signal Name | I/O | State | Function |
|------|-------------|-----|-------|-----------------------------|
| 1 | NC | - | - | - |
| 2 | VDD | - | - | 3.3V power input |
| 3 | GND | - | - | Power-supply ground |
| 4 | TXD | O | - | TTL level 232 transmit data |
| 5 | RXD | I | - | TTL level 232 receive data |
| 6 | USB_D- | - | - | USB_D- signal |
| 7 | USB_D+ | - | - | USB_D+ signal |
| 8 | NC | - | - | - |
| 9 | BUZ | I | - | Beeper input |
| 10 | LED | I | - | Good Read LED input |
| 11 | nRST | O | - | Reset signal output |
| 12 | nTRIG | O | - | Trigger signal output |

The 12-PIN connector is shown as below.

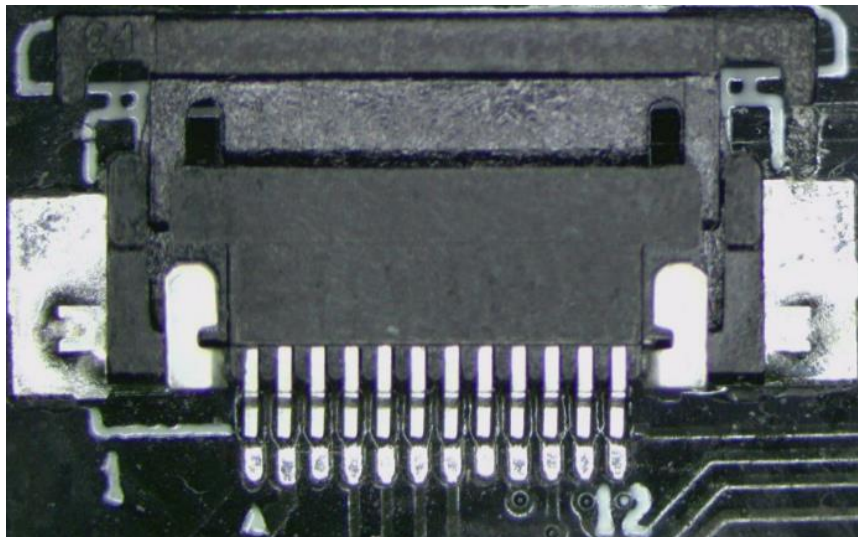

Figure 3-2

Connector Specifications

The N1 is equipped with a 13-pin FPC connector. The connector is supplied by Hirose Electric Co.Ltd, Model No.: FH35C-13S-0.3SHW(50). For more information about the connector, please visit <https://www.hirose.com/>.

Note:

1. In order to improve the connecting stability,using the downward connection priority.
2. Do not close the connector before inserting the FPC cable.
3. Please avoid operating the connector more times.

Chapter 4 Electrical Specifications

Power Supply

Do not power up the N1 until it is properly connected. Be sure the power is cut off before connecting a cable to or disconnecting a cable from the host interface connector. Hot-plugging could damage the engine.

Unstable power supply or sharp voltage drops or unreasonably short interval between power-ons may lead to unstable performance of the engine. Do not resupply the power immediately after cutting it off.

※ When designing, the user should ensure that the input power of N1 is fully decoupled. It is recommended to place a 22uF and a 100nF X5R or X7R ceramic capacitor beside the power input pin on the connector which is soldered on the board. The capacitor mounted on the external input power supply is recommended to be controlled within 50uF.

※ Ensure that the input power drops below 0.5V before powering the N1 on again, otherwise it will lead to abnormal function.

Ripple Noise

To ensure the image quality, a power supply with low ripple noise is needed.

Acceptable ripple range (peak-to-peak) : $\leq 100\text{mV}$

DC Characteristics

Operating Voltage

Table 4-1

T=25°C

| Parameter | Description | Minimum | Typical | Maximum | Unit |
|-----------|---------------|---------|---------|---------|------|
| VDD | Input Voltage | 3.14 | 3.3 | 3.47 | V |

Operating Current

Table 4-2

T=25°C

| Description | State | PEAK | RMS | Unit |
|-----------------|----------|------|------|------|
| Working Current | VDD=3.3V | 240 | 138 | mA |
| Standby Current | | - | 11.8 | mA |

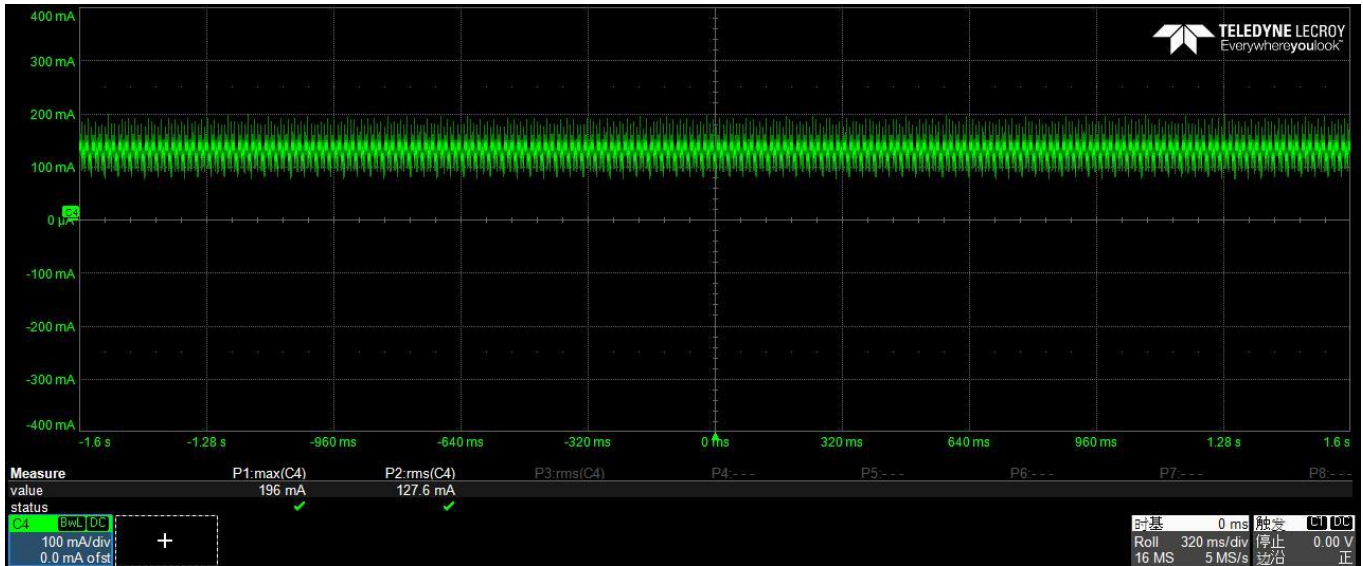

Working Current
Figure 4-1

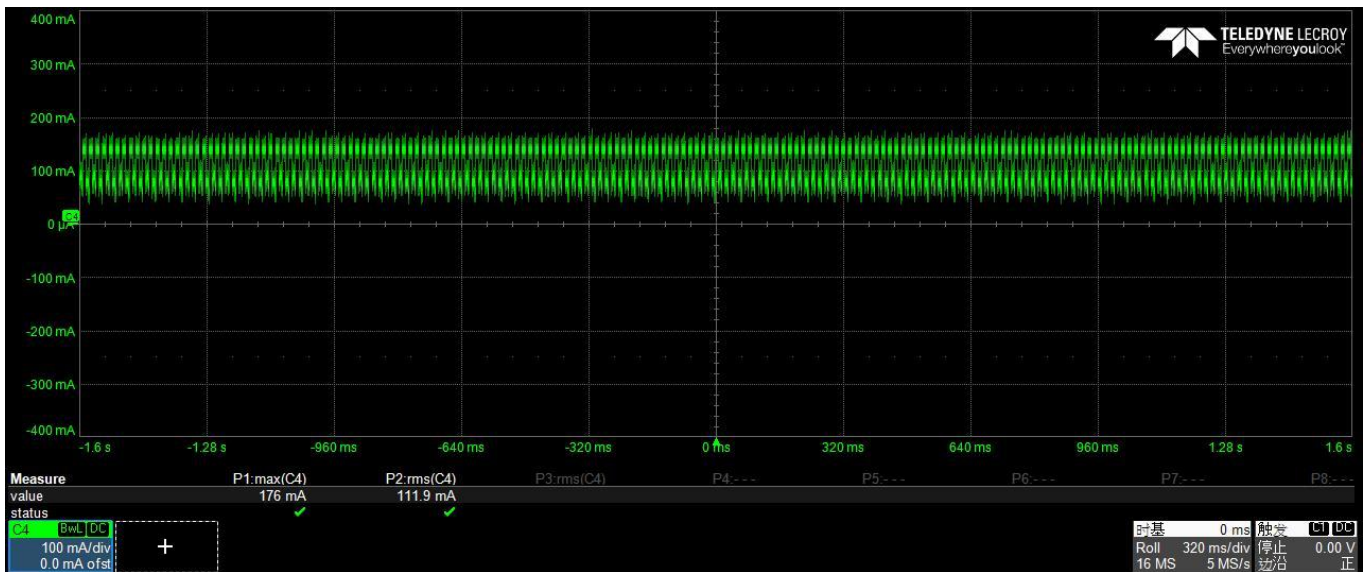

Working Current (Aimer off)
Figure 4-2

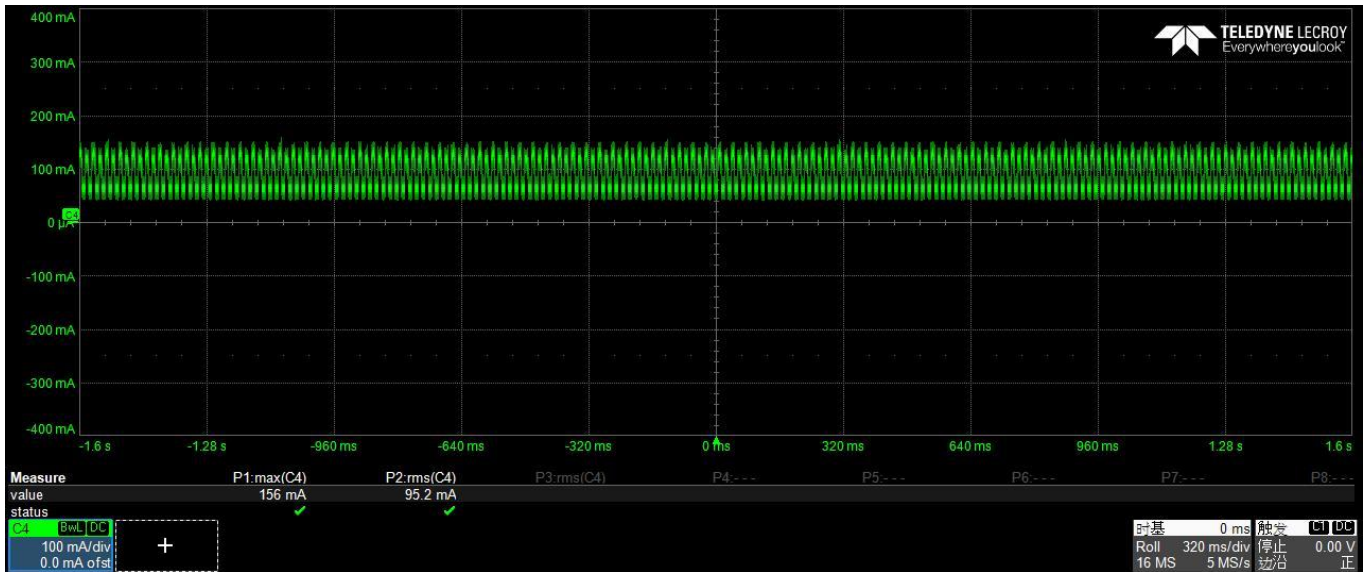

Working Current (Illumination off)

Figure 4-3

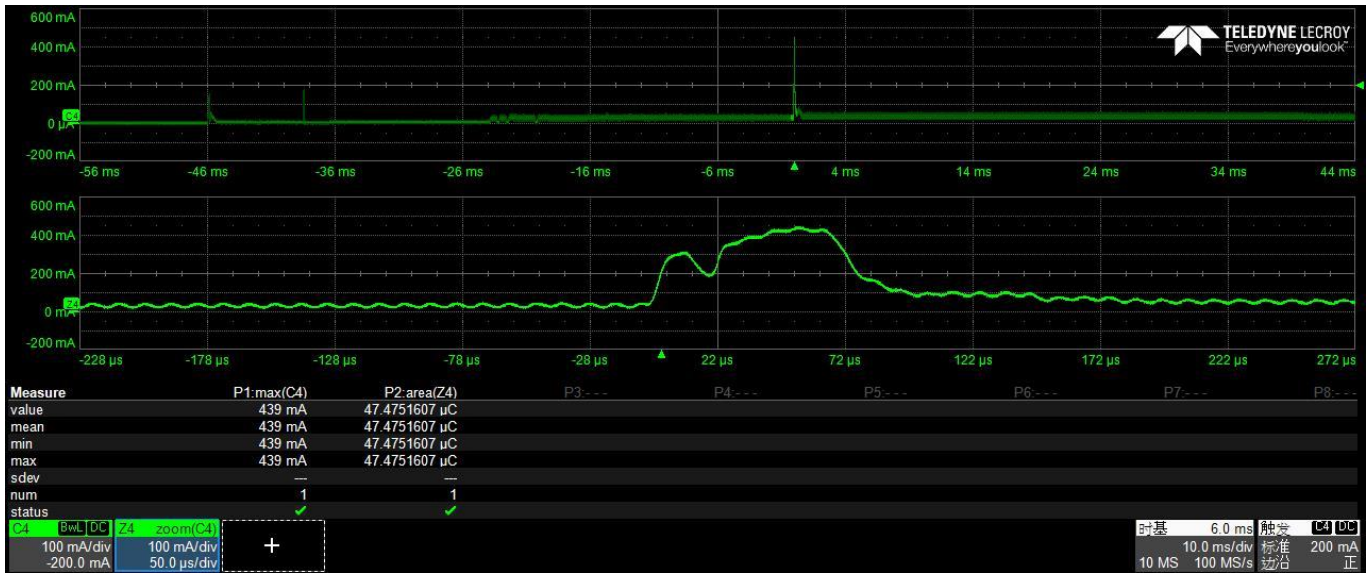

Max Impulse Current When Powered On

Figure 4-4

The max impulse current (439mA) when powered on is shown in Figure 4-4. It is recommended that the external VDD should provide at least a current of 500mA. Ensure that Rdc of the cable is controlled within 0.35Ω by shortening FPC cable, increasing power line and ground line width, etc. Avoid using long cables to connect the N1. Power consumption will result in abnormal function.

I/O Voltage

Table 4-3

VDD=3.3 V, GND =0 V, T=25°C

| Parameter | Condition | Minimum | Typical | Maximum | Unit |
|--------------------|------------------|---------------|---------|---------------|------|
| VIL | Except nTRIG pin | - | - | 0.8 | V |
| VIH | Except nTRIG pin | 2 | - | - | V |
| VIL ⁽¹⁾ | Only nTRIG pin | - | - | 2.2 (VDD-1.1) | V |
| VIH ⁽¹⁾ | Only nTRIG pin | 2.9 (VDD-0.4) | - | - | V |
| VOL | Iol= 4mA~16mA | | - | 0.4 | V |
| VOH | Ioh= 4mA~16mA | 2.4 | - | - | V |

Note: The high and low level threshold of nTRIG is related to the external voltage VDD. The input low level VIL of nTRIG should be below VDD-1.1, and the input high level VIH should be above VDD-0.4.

Timing Sequence

Power Up Timing Sequence

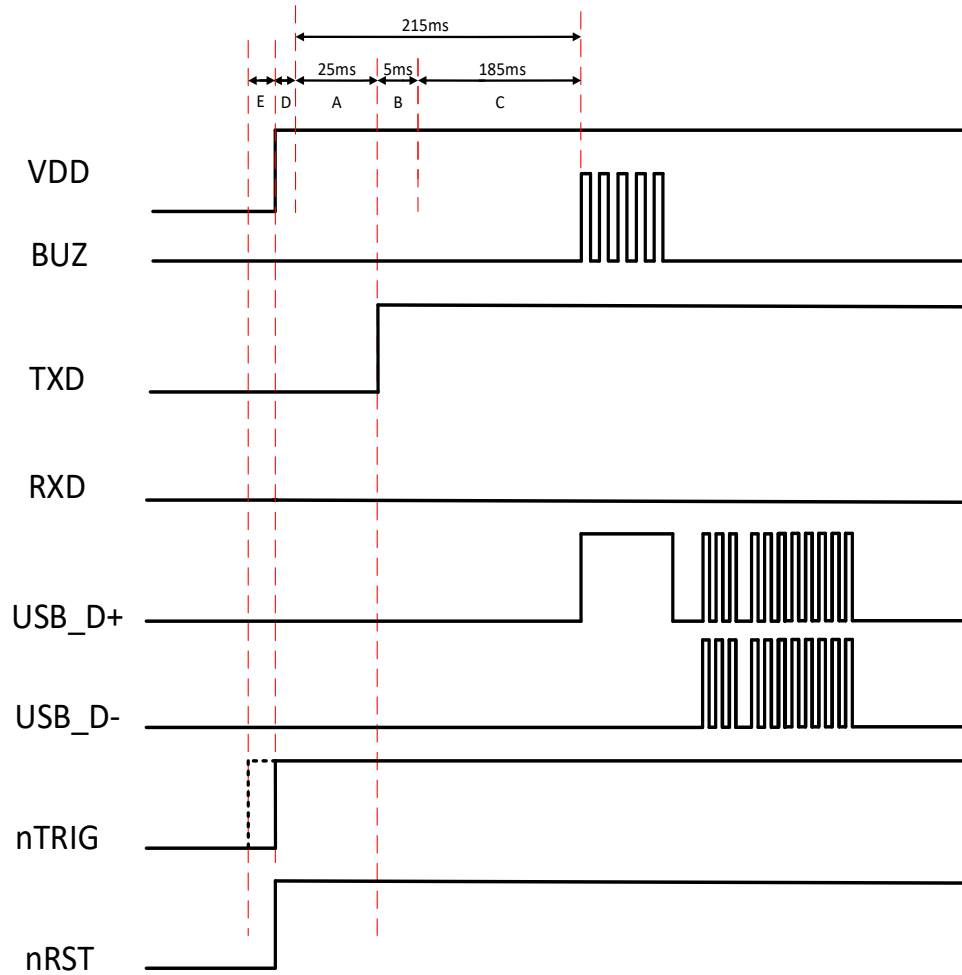
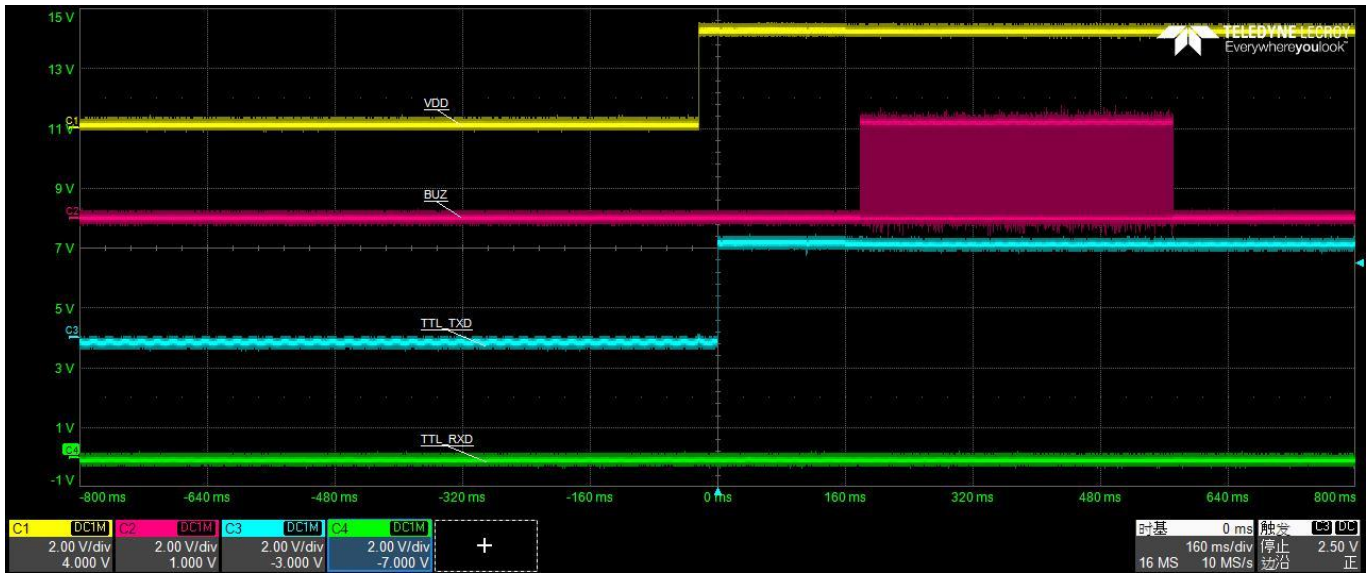

Figure 4-5

1. In the diagram above, it takes **A+B+C** (about 215ms) for the engine to power up: **A** is bootloader execution time (25ms), **B** is kernel boot time (5ms) and **C** is decoding chip initialization time(185ms).
2. D is reset time (300us). If the Reset signal is not operated when powered on, the startup time should be calculated after VCC_3V3 reaches 3.3V.
3. Ensure that all communication interface data has been transmitted before powering off.
4. The N1 has a 100K pull-up on the nTRIG signal. During the period between power-on and bootloader execution, the user should not lower the nTRIG signal. If nTRIG is set high before power-on, it should meet the duration of E (E=0~1ms) as shown in Figure 4-4. Levels of other signals are kept low during power-on to prevent abnormal function.



Power Up Timing Sequence (Serial Interface)

Figure 4-6



Power Up Timing Sequence (USB)

Figure 4-7

Power Down Timing Sequence

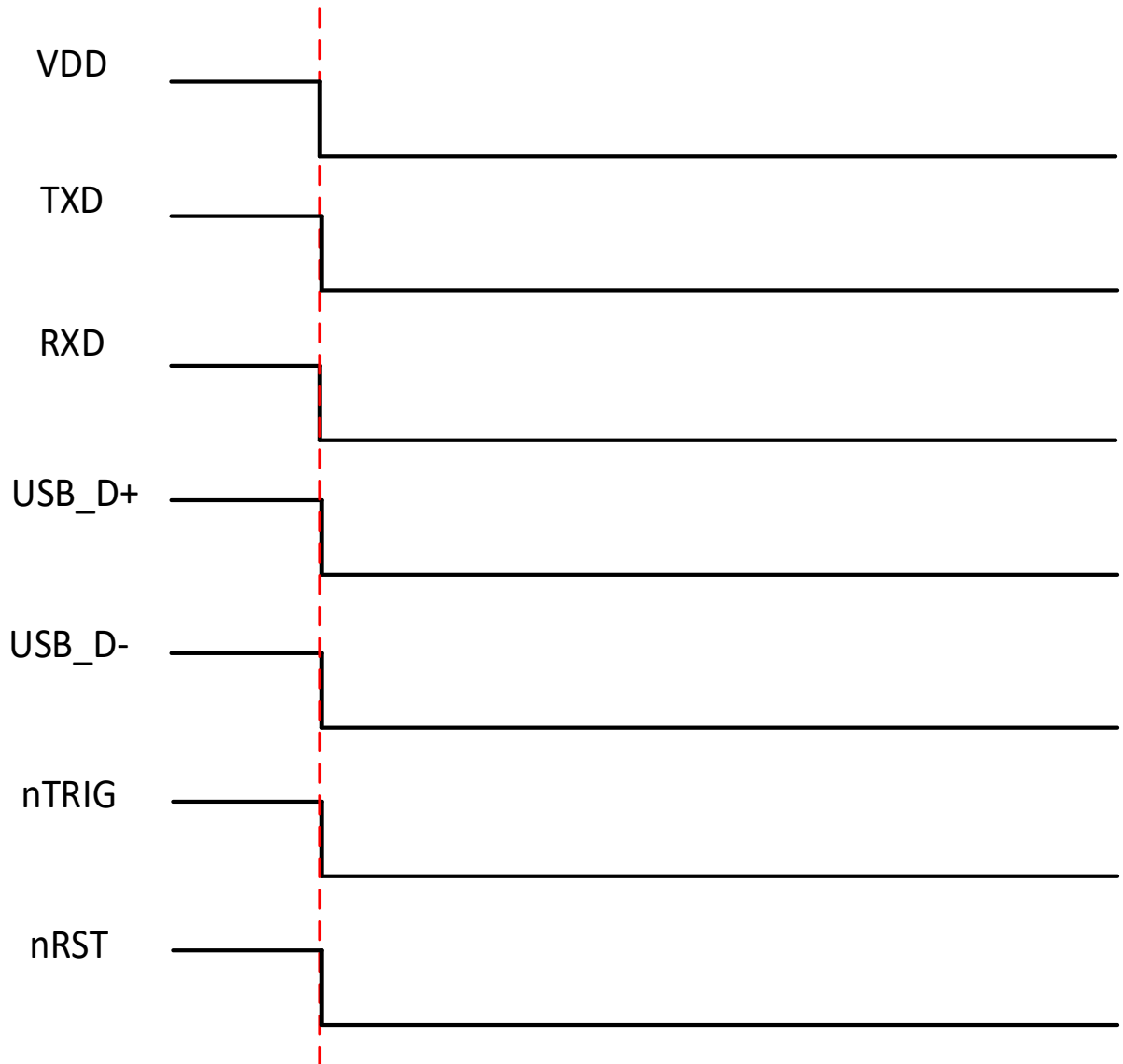

Figure 4-8

Note: When powering down the N1, cut off the power and ensure levels of TXD, RXD, USB_D+, USB_D-, nTRIG and nRST signal are kept low.

Chapter 5 Interfaces

External Circuit Design

Good Read LED Circuit

The circuit below is used to drive an external LED for indicating good read. The nGoodRead signal is from PIN 4 of the 13-pin FPC connector.

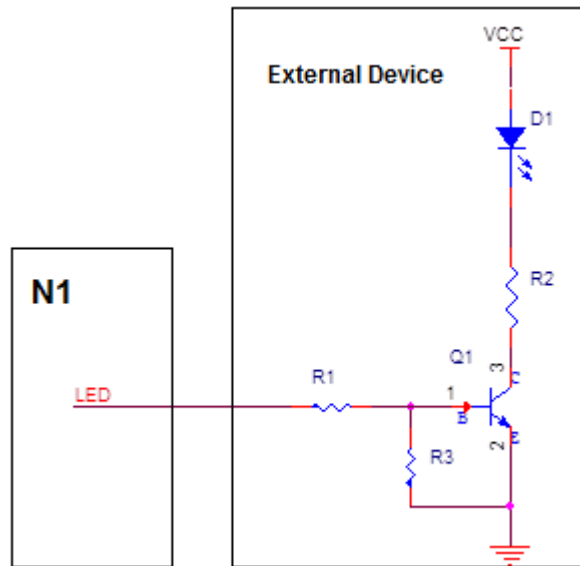

Figure 5-1

Beeper Circuit

The circuit below is used to drive an external beeper. The nBEEPER signal is from PIN 5 of the 13-pin FPC connector.

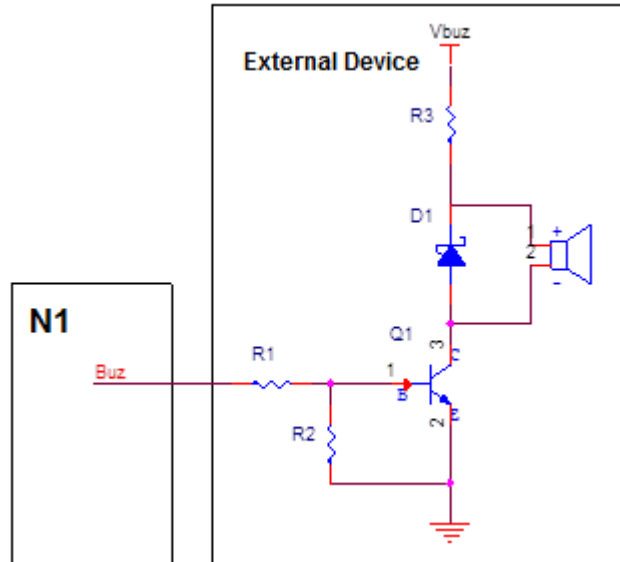

Figure 5-2

Trigger Circuit

The circuit below is used to provide the engine with a signal to trigger a scan and decode session. The nTRIG signal is from PIN 2 of the 13-pin FPC connector.

The host can adjust the external circuit and its functions based on actual applications. R1 is recommended as 10K-100K and R2 as 33Ω. C1 is used to eliminate the vibration of mechanical keys. Generally, 1nF-10nF ceramic capacitors are recommended. When ESD protection is required, ESD protector can be added to the external circuit like ED1 shown as below.

When using the external IO port as a trigger output, note that high and low levels must meet the requirements provided in Table 4-3. It is recommended to use the default floating or default pull-up IO port as the trigger pin. If you can only use the default pull-down IO port as the trigger pin, refer to the power-on timing sequence in Figure 4-5. When not triggered, ensure that the pin meets the high level requirements in Table 4-3.

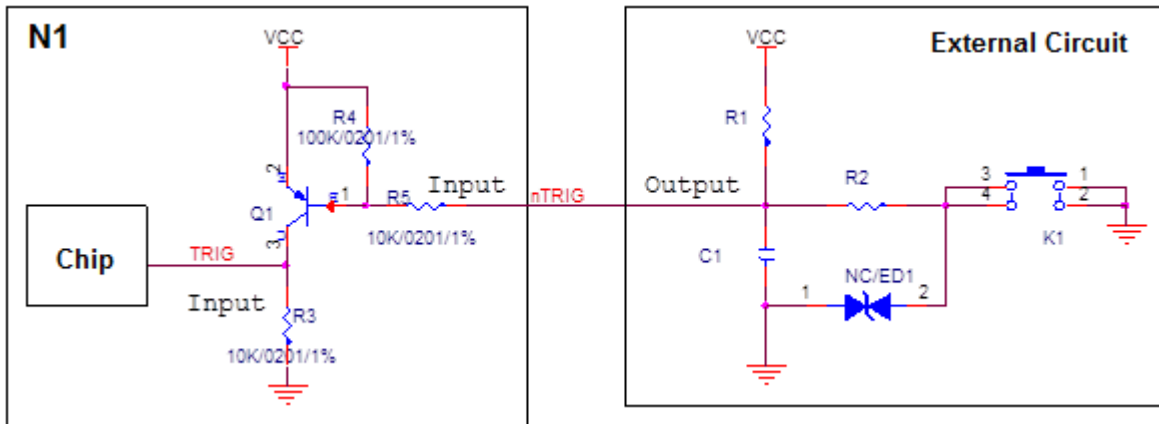

Figure 5-3

External Illumination Control Circuit

Pin 6 (Ext.LED.Ctrl) on the 13-pin FPC connector is the external illumination control signal. I/O is in the Floating state before initialization. When the external illumination is not enabled, I/O is configured as the input pin. When enabled, I/O is the output pin in working mode and input pin in the sleep mode. For external illumination, please refer to the user guide for software configuration. The duration from the Ext LED Ctrl signal output to the external illumination should not exceed 100us.

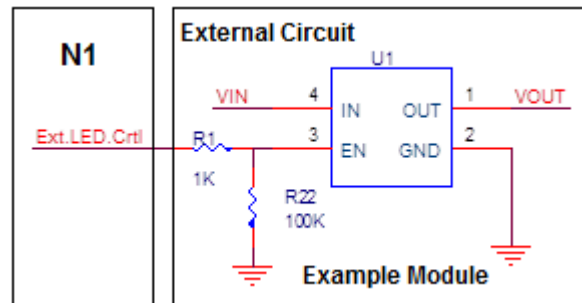

Figure 5-4

Chapter 6 Auxiliary Tools

The N1 provides the following two tools to assist users in engine performance evaluation, application development and engine configuration.

EVK

The EVK is provided to help users to test and evaluate the N1, which contains beeper & beeper driver circuit, LED & LED driver circuit, and trigger, TTL-232 to RS-232 converter, RS-232 & USB interfaces, reserved signal debugging interface, etc. The N1 can be connected to the EVK via a 13-pin FPC cable to 12-PIN FPC cable.

EasySet

EasySet is a Windows-based configuration tool developed by Newland, which can be used to configure the N1.



Newland

SCANNING MADE SIMPLE

Newland EMEA HQ

+31 (0) 345 87 00 33
info@newland-id.com
newland-id.com

D-A-C-H

+49 (0) 6182 82916-16
info@newland-id.de

Benelux

+31 (0) 345 87 00 33
benelux@newland-id.com

Italy

+39 (0) 342 0562227
italy@newland-id.com

United Kingdom

+44 (0) 1442 212020
sales@newland-id.co.uk

South Africa

Gauteng: +27 (0) 11 553 8010
Cape Town: +27 (0) 21 9140819
info@newland-id.co.za

Turkey

+90 (0) 544 538 40 49
turkey@newland-id.com

France

+39 (0) 345 8804096
france@newland-id.com

Ibérica

+34 (0) 93 303 74 66
info@newland-id.es

Nordic & Baltic

+46 (0) 70 88 47 767
nordic@newland-id.com

Russia

+31 (0) 345 87 00 33
russia@newland-id.com

Middle East

+39 (0) 345 8804096
middleeast@newland-id.com

Iran

+90 (0) 544 538 40 49
iran@newland-id.com